

Wireless World

RADIO AND ELECTRONICS



SEPT. 1949

2/-

Vol. LV. No. 9

IN THIS
ISSUE :

NEW BROADCAST RECEIVER PROBLEM

FREE to all RADIO ENGINEERS

B.I. Callender's

RADIO CONNECTING WIRES

BRITISH INSULATED CALLENDER'S CABLES LIMITED

STAND 55
RADIO EXHIBIT
SEP 28-30 OCT 1

This publication is of importance to radio engineers. It gives useful information on the range of connecting wires and sleeving made by BICC to meet the requirements of the Radio and Telecommunication industry.

Write to-day for Publication 247T



**BRITISH INSULATED CALLENDER'S CABLES LIMITED
NORFOLK HOUSE, NORFOLK STREET, LONDON, W.C.2**

Another worthy addition

TO THE RANGE OF

'AVO' Test Instruments

A new Signal Generator of wide range and accuracy of performance, designed for use in the laboratory or by the service engineer. Turret coil switching provides six frequency bands covering 50 Kc/s to 80 Mc/s:—

50 Kc/s—150 Kc/s	1.5 Mc/s—5.5 Mc/s
150 Kc/s—500 Kc/s	5.5 Mc/s—20 Mc/s
500 Kc/s—1.5 Mc/s	20 Mc/s—80 Mc/s

Note these Attractive Features:

Stray field less than $1\mu\text{V}$ per metre at a distance of 1 metre from instrument. General level of harmonic content of order of 1 per cent.

Direct calibration upon fundamental frequencies throughout range, accuracy being better than 1 per cent. of scale reading.

45 inches of directly calibrated frequency scales with unique illuminated band selection giving particularly good discrimination when tuning television "staggered" circuits.

Of pleasing external appearance with robust internal mechanical construction using cast aluminium screening, careful attention having been devoted to layout of components with subsidiary screening to reduce the minimum signal negligible level even at 80 Mc/s.

Four continuously attenuated ranges using well designed double attenuator system.

Force output 0.5 volts.

Internal modulation at 400 c/s., modulation depth 30 per cent., with variable L.F. signal available for external use.

Mains input 100-250 volts A.C., 40-60c/s.

Battery Model available having same general specification and covering 50 Kc/s—70 Mc/s., powered by easily obtainable batteries.

Fully descriptive pamphlet available on application

Sole Proprietors and Manufacturers:



Mains Model

£25

Battery Model

£24

RADIOLYMPIA
See our Exhibit at
Stand No.85

Sept. 28—Oct. 8

The AUTOMATIC COIL WINDER & ELECTRICAL EQUIPMENT CO. LTD.
WINDER HOUSE • DOUGLAS STREET • LONDON • S.W.1 Telephone: VICTORIA 3404/9

SG. 1

Radiolympia Preview

STAND No. 81 GRAND HALL

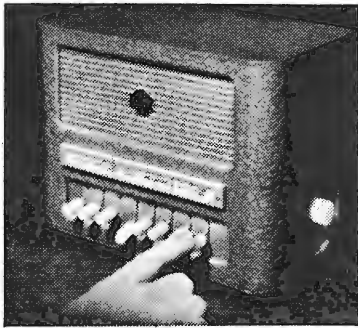

TELEMASTER INTERESTING NEW INTERCOMM. DEVELOPMENTS.

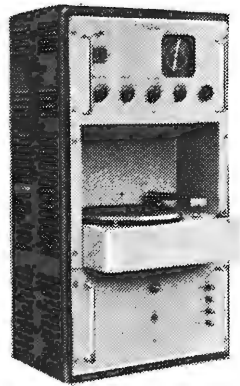

INDUSTRIAL SOUND INSTALLATIONS.



DIRECT DISK RECORDING OUTFIT. HIGH FIDELITY DISK RECORDING.

★

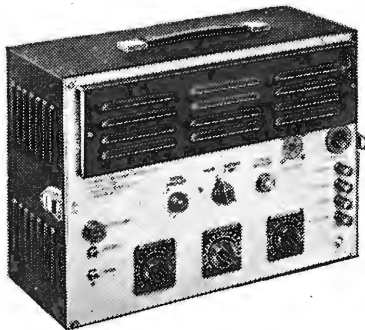

P.A. 20B AMPLIFIER. PORTABLE & MOBILE AMPLIFIERS.

★

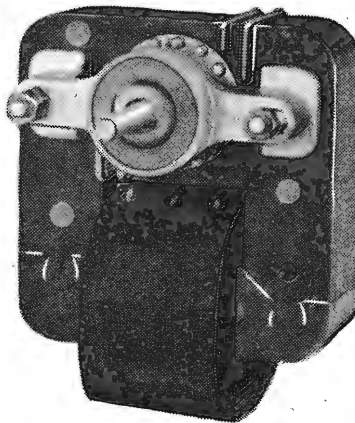

S.R. 2 MOTOR UNIT. SHADED POLE MOTORS.

★

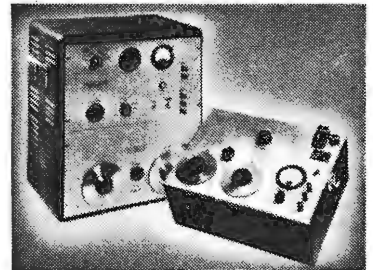

L.O.80 and L.O.50 OSCILLATORS. BEAT FREQUENCY OSCILLATORS AND LABORATORY INSTRUMENTS

★

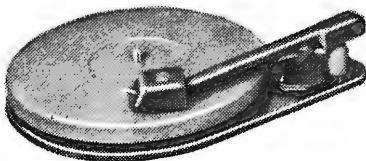

G.U.2 GRAMOPHONE UNIT.



MEET US AT
RADIOLYMPIA
SEPT 28 - OCT 8

BIRMINGHAM SOUND REPRODUCERS LTD.,
CLAREMONT WORKS, OLD HILL, STAFFS. Tel.: Cradley 6212.3

Wireless World

RADIO AND ELECTRONICS

SEPTEMBER

1949

39th YEAR OF PUBLICATION

Proprietors : ILIFFE & SONS LTD.
 Managing Editor : HUGH S. POCOCK, M.I.E.E.
 Editor : H. F. SMITH

Editorial, Advertising and Publishing Offices :
 DORSET HOUSE, STAMFORD STREET,
 LONDON, S.E.1.

Telephone : Waterlooo 3333 (60 lines).
 Telegrams : "Ethaworld, Sedist, London."

PUBLISHED MONTHLY

Price : 2/-

(Publication day : last Thursday of preceding month)

Subscription Rate : 26/- per annum. Home and Abroad

Branch Offices :

Birmingham : King Edward House, New Street, 2.
 Coventry : 8-10, Corporation Street.
 Glasgow : 26B, Renfield Street, C.2.
 Manchester : 260, Deansgate, 3.

In This Issue

OUR COVER : Sutton Coldfield Television Aerial (See Page 357)

EDITORIAL COMMENT	321
INTERMEDIATE FREQUENCY AND THE COPENHAGEN PLAN. By G. H. Russell	322
VALVE MEGOHMMETER. By W. H. Cazaly	326
DIVERSE VIEWS ON "DIVERSITY"	329
SHORT-WAVE CONDITIONS	330
AUDIO SIGNAL GENERATOR. By M. G. Scroggie	331
DUAL CONCENTRIC LOUDSPEAKER	334
TEST REPORT : EDDYSTONE MODEL 680	335
NORTH AMERICAN BROADCASTING. By R. H. Tanner	339
WORLD OF WIRELESS	341
DECCA RADAR	345
ELECTRONIC CIRCUITRY. By J. McG. Sowerby	346
GENERALIZED GRAPHS. By "Cathode Ray"	349
UNBIASED. By "Free Grid"	354
LETTERS TO THE EDITOR	355
RANDOM RADIATIONS. By "Diallist"	358

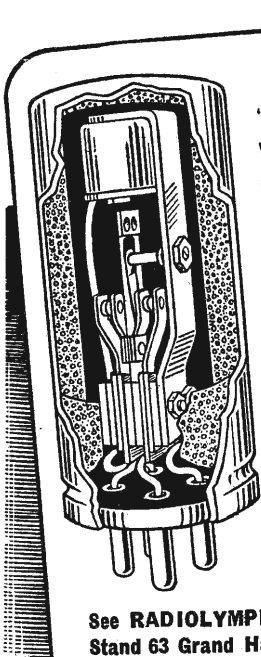

"Stratosil" fully sealed vibrators are supplied in synchronous, non-synchronous and split-reed synchronous types. Being available in both shunt and series drive (the latter being made under "OAK" patents) they offer a replacement service for the majority of American-pattern vibrators as well as covering fully the needs of the designer of new equipments.

See **RADIOLYMPIA**
 Stand 63 Grand Hall

WEARITE

VIBRATORS

*set the standard
 for efficiency*

A data book, complete with replacement guide and transformer design information is now ready and will be gladly sent to you at 6d. post free. Please use the coupon.

POST THE COUPON NOW

Wright & Weaire, Ltd., 138 Sloane Street,
 London, S.W.1, England
 Please send me VIBRATOR DATA BOOK for which I enclose 6d.
 Name and Address

WW 949

Wright and Weaire Limited

138, SLOANE ST. · LONDON · S.W.1 TEL SLOANE 2214/5 FACTORY: SOUTH SHIELDS, CO. DURHAM

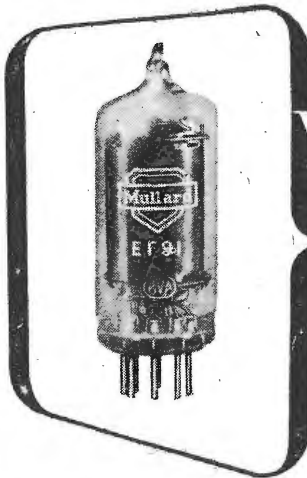

Valves and their applications

EF91 IN HIGH-FREQUENCY RECEIVER CIRCUITS

In high-frequency receivers, a high-slope pentode is almost indispensable. Apart from applications in audio and control circuits, it can be used successfully in R.F., I.F., mixer and

oscillator stages provided that its high-frequency performance is adequate. Although the high-slope pentode is inferior in some respects when compared with special circuits (e.g. the EC91 grounded-grid amplifier described in the March issue of *Wireless World*), in many applications, in particular when economy of valve types is desirable, the versatility of the pentode is of great value.

The EF91 is a miniature high-slope pentode on the B7G base, specifically designed for high frequencies. It has wide application in television, F.M., and V.H.F. communication receivers of all types. This article gives some of the performance data in R.F., I.F., mixer and oscillator circuits. More detailed descriptions of circuits using the EF91 will be given in future articles. The static characteristics are listed in Table 1.

TABLE I

$V_a = 250 \text{ V}$	$r_a = 1.0 \text{ M}\Omega$
$V_{g2} = 250 \text{ V}$	$\mu_{g1-g2} = 70$
$I_a = 10 \text{ mA}$	$V_h = 6.3 \text{ V}$
$I_{g2} = 2.5 \text{ mA}$	$I_h = 0.3 \text{ A}$
$V_{g1} = -2 \text{ V}$	$C_{in} = 7.0 \mu\text{F}$
$g_m = 7.65 \text{ mA/V}$	$C_{out} = 2.0 \mu\text{F}$
	$C_{a-g1} < 0.008 \mu\text{F}$

R.F. Amplifier

The important features of a R.F. amplifier valve are slope, input and output impedances, noise factor and feedback capacitance, since these determine the gain, bandwidth, signal-to-noise ratio and stability. It can be seen from Table 1 that the EF91 slope is high and the feedback capacitance (C_{a-g1}) is low.

The input resistance at 50 Mc/s is 7,500 ohms and varies approximately inversely as the square of the frequency. The product of slope and input resistance is therefore unity at about 350 Mc/s. The input and output capacitances are low so that wide bandwidths can be obtained.

Due to the relatively high external noise level at frequencies less than about 60 Mc/s the EF91 valve noise is relatively small. At higher frequencies, however, valve noise is important. The equivalent noise resistance of the EF91 is 1200Ω but a better measure of the noise performance is the noise factor. Figures measured at 50 Mc/s and 180 Mc/s are 2.7 (4.3dB) and 10.5 (10dB) respectively. The corresponding sensitivities, expressed as the open circuit voltages at the aerial terminals for unity signal-to-noise ratio and 200 Kc/s bandwidth are 0.8μV and 1.7μV. These figures refer to the signal-to-noise ratio as measured in front of the second detector. The signal-to-noise ratio in the output circuits

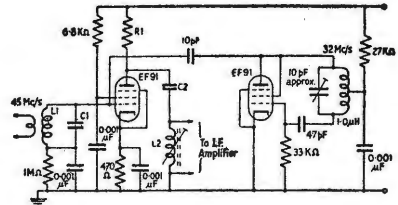

The signal frequency input circuit consists of L1 and C1. R1, C2 and L2 form the first I.F. circuit, resonant at 13 Mc/s. FIG. 1

will be considerably greater than unity if the overall bandwidth of the receiver is less than 200 Kc/s.

Mixer and Oscillator

As a mixer the EF91 gives a conversion conductance of 3mA/V and since the input resistance as a mixer is about twice that as an amplifier, it can be used successfully in combination with an EF91 R.F. amplifier. A typical frequency-changer circuit using two EF91s as mixer and oscillator at television frequencies is shown in Figure 1. The grid to anode voltage gain of this circuit with a 3000Ω I.F. load is 9 times.

Two advantages of the EF91 mixer as compared with a triode-hexode frequency changer are its high gain and low noise level. The equivalent noise resistance is 6,500Ω and the noise factor at 45Mc/s is 10 (10dB). The mixer noise is negligible when one R.F. stage is used. To take a typical example of a receiver at 100 Mc/s with an EC91 R.F. amplifier, the EF91 mixer and subsequent stages contributed less than 1dB to the overall noise factor.

I.F. Amplifier

In a high gain I.F. amplifier the important factors are slope and input and output capacitances. The ratio $g_m/(C_{in} + C_{out})$ is a useful figure of merit for I.F. valves, since it is a measure of the gain and bandwidth product. The figure of merit for the EF91 is higher than that for any other current high-slope pentode.



Reprints of this report from the Mullard Laboratories, may be obtained free of charge from the address below.

MULLARD ELECTRONIC PRODUCTS LTD.,
TECHNICAL PUBLICATIONS DEPARTMENT,
CENTURY HOUSE, SHAFTESBURY AVE., W.C.2
(MYM102)

Wireless World

VOL. LV. NO. 9

SEPTEMBER 1949

RADIO AND ELECTRONICS

MONTHLY COMMENTARY:

Spreading Television

THERE has been much talk of late on extending our television service to cover more of the country, but regrettably few signs of anything that seems likely to produce rapid and tangible results. But unless something is done quickly to give us nation-wide coverage, it will be increasingly hard to convince overseas customers that this country, which was the first to inaugurate a regular television service, still has, in fact, the necessary "know how" to design and manufacture television equipment. Our present service of one station in operation and another due to open in the autumn seems insignificant alongside the almost astronomical figures given in the recently announced American allocations. Without a flourishing home industry, British television must eventually sink to a position of insignificance.

HOWEVER, there are a few gleams of hope. The increase of television coverage has been debated at some length in Parliament, though primarily from the somewhat limited point of view of providing Scotland with a service. We were glad to see that several Members—and Scottish ones at that—admitted the subject of the debate should have been "Television for Britain." In our view, the fundamental organization of our whole broadcasting system is such that it cannot properly be considered on a narrow regional basis. This is particularly true of television, where the linking network of radio links or r.f. cables must be integrated from the centre. Programme costs are so high that independent stations, depending entirely on their own sources of material, can hardly be expected to survive economically. It would be a pity if "pressure group" tactics were allowed to upset plans for orderly and rational development.

Although the usefulness of the debate was to some extent marred by what we may call, without

affront to Scotland, somewhat extraneous matters, one or two points of importance came to light. The Assistant Postmaster-General expressed the Government's sympathy with proposals to extend the service and went on to say that the matter was really the responsibility of the B.B.C. After the end of this year there would be no bar on the extension of television and the B.B.C. will be free to use its very considerable financial resources for this purpose. Any hopes that may have been raised by this reassuring pronouncement were somewhat dashed when the Asst. P.M.G. went on to say that restrictions on capital expenditure might cause delay, and television was regarded as being of low priority.

Wireless World is, of course, biased, and can think of other national activities at present flourishing which should enjoy a much lower priority. Be that as it may, it seems a pity that the start in television which we won should be lost through unwillingness to allot a trivial part of our national resources to its development.

A MORE cheering, though perhaps not highly significant, piece of news comes from the C.C.I.R. conference at Zurich in the shape of a report—without any details—that France has agreed to adopt the British standard of 405 lines (in place of 455 lines). It is not yet clear if this is to be an arrangement of long duration or merely an interim measure to be adopted until the proposed 819-line French standard is adopted. Either way, it is at least a step in the right direction. The burden of programme costs is a heavy one for a war-impooverished Europe, and anything that makes possible international exchanges is to be welcomed. *Wireless World* considers the British 405-line standard to be the most practical one for Europe, and we hope it is now to be given a chance of proving itself on the Continent.

INTERMEDIATE FREQUENCY

New and Serious Interference Problem

By G. H. RUSSELL, (Vidor Ltd.)

WHEN the new frequency allocations were published* last year, it became apparent that the popular intermediate frequencies of 456 and 465 kc/s would no longer be suitable, as they would cause interference whistles, of the type peculiar to superheterodyne receivers, to occur on channels allocated to the B.B.C. The matter was then investigated more fully with a result which is rather startling.

The whole problem centres around the commercially produced simple superheterodyne re-

ceiver with one tuned circuit between the aerial and frequency-changer which is the type used by the majority of listeners in this country to-day. Although this type of receiver is susceptible to whistles produced in a number of different ways, upon checking a number of different models of various manufacture it was found that only three types were liable to cause serious interference. These are (1) i.f. harmonic; (2) second channel, and (3) oscillator second harmonic. Very generalized figures of interference inputs required to produce quite annoying whistles are: second channel m.w., 20-30 μ V; second channel

wave band 525-1605 kc/s, and the large increase of aerial power permitted in many cases.

The B.B.C. have been granted the use of one long-wave channel (200 kc/s, Light Programme, Droitwich, 400 kW), and fifteen medium-wave channels, of which two are for European broadcasting (1295 kc/s, Ottringham, 150 kW, and 1340 kc/s, Crowborough, 150 kW). Another two are low power (2 kW maximum, International Common Frequency channels referred to as I.C.F. in this article). The remaining channels are to be used as shown in Table I on the opposite page.

The available band for intermediate frequency use is 300-500 kc/s, and it would obviously be a

Fig. 2. I.F. third harmonic interference: diagonal solid line represents actual i.f. and chain lines area over which whistles may be expected. Use as Fig. 1.

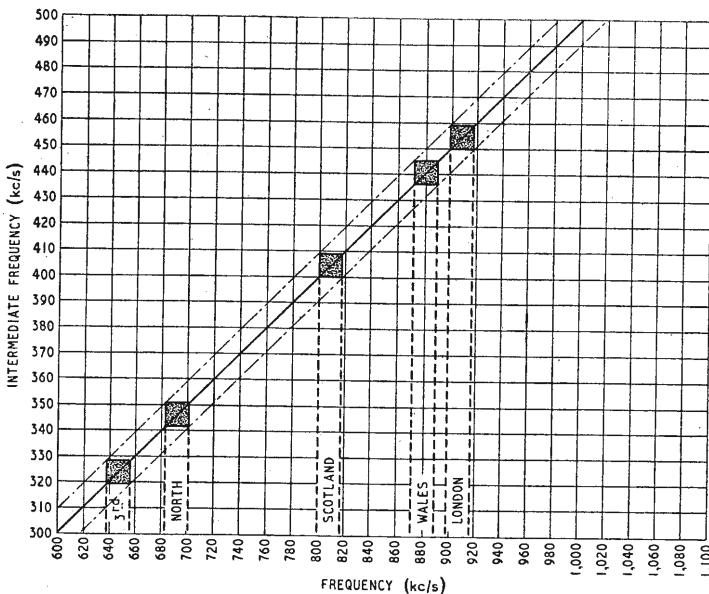
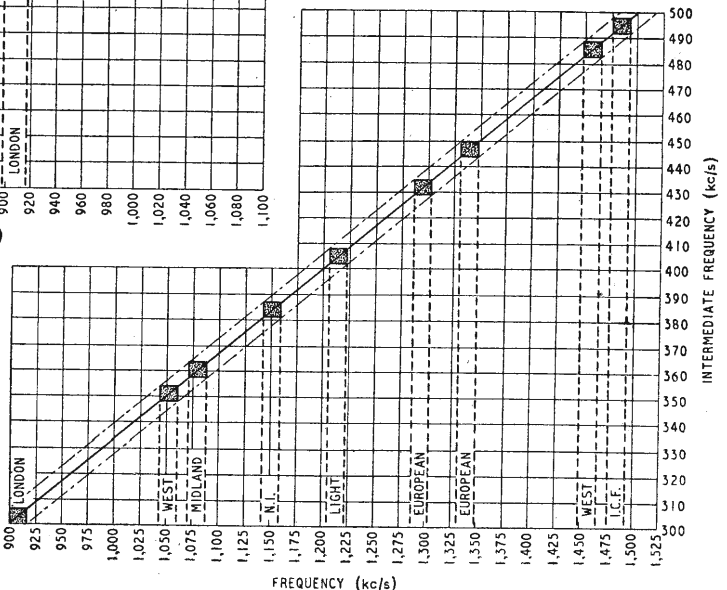

Fig. 1. I.F. second harmonic interference: diagonal solid line represents actual i.f. and chain lines area over which whistles may be expected: dotted vertical lines represent transmitter carrier plus sidebands. Any i.f. cutting across shaded position may be expected to produce whistles on that particular channel to which shaded portion refers.



ceiver with one tuned circuit between the aerial and frequency-changer which is the type used by the majority of listeners in this country to-day. Although this type of receiver is susceptible to whistles produced in a number of

l.w., 1-2 mV; oscillator second harmonic, 30-40 mV. The position will be aggravated under the plan because of the extended medium

very tedious process to work out arithmetically the effect of different intermediate frequencies on the interference possibilities be-

* See *Wireless World*, Nov., 1948.

AND THE COPENHAGEN PLAN

tween these sixteen channels. The problem was therefore attacked by means of the accompanying graphs, which deal with the three main causes of whistles mentioned

used in the same way; the channel interfered with is read off the vertical scale and the interfering channel read off the horizontal scale. Here again, pairs of dotted

lines whose lines cross a shaded area were to be used as the i.f. of a receiver, whistles may be expected on the vertical scale channel caused by the corresponding channel on the horizontal scale. Note that in the case of oscillator second harmonic interference, the sidebands of the interfering transmitter are ± 4.5 kc/s, and in the case of second channel interference ± 9 kc/s.

TABLE I

647 kc/s	3rd Programme	(Burghead, 15; Droitwich, 120; Stagshaw, 15; Westerglen, 15.)
692 kc/s	North Home Service...	(Moorside Edge, 150.)
809 kc/s	Scottish Home Service	(Burghead, 100; Dundee, 5; Redmoss, 20; Westerglen, 100.)
881 kc/s	Welsh Home Service...	(Aberystwyth, 5; Penmon, 20; Washford, 150; Wrexham, 5.)
908 kc/s	London Home Service	(Brookman's Park, 150.)
1052 kc/s	West Home Service	(Hartland Point, 10; Start Point, 150.)
1088 kc/s	Midland Home Service	(Droitwich, 150; Norwich, 20.)
1151 kc/s	North and Northern Ireland Home Service	(Carlisle, 5; Lisnagarvey, 100; Londonderry, 5; Stagshaw, 100.)
1214 kc/s	Light Programme	(Ayr, 5; Brookman's Park, 60; Burghead, 20; Dundee, 5; Lisnagarvey, 10; Londonderry, 1; Moorside Edge, 58; Plymouth, 2; Redmoss, 2; Redruth, 2; Stagshaw, 10; Westerglen, 50.)
1457 kc/s	West Home Service	(Bartley, 60; Clevedon, 60.)
1546 kc/s	3rd Programme	(London, 20; and 21 transmitters of 2 or 5 kW each serving most of the large towns.)

Figures refer to maximum aerial powers usable under the Plan.

above, and should present no difficulties when used correctly.

Figs. 1 and 2 deal with 2nd and 3rd i.f. harmonic interference respectively; the diagonal solid line should be used to determine the central frequency upon which the interference will appear, and the chain lines, the frequency band which the interference will cover.

Dotted vertical lines have already been drawn in, each pair representing one B.B.C. carrier plus its sidebands. Where these cut across the area between the chain lines, this section has been shaded in, and the intermediate frequencies which will cause whistles on any particular station can be read off the vertical scale from bottom to top of the shaded area. As an example of each, any i.f. between 449.5 and 458.5 kc/s will produce whistles on London Home Service channel, 908 kc/s, Fig. 1; any i.f. between 401.6 and 407.6 kc/s will produce whistles on Light Programme channel, 1214 kc/s, Fig. 2.

Figs. 3 and 4 deal with second channel interference appearing on long wave (140-300 kc/s) and medium wave (500 to 1,000 kc/s) respectively. Figs. 5 and 6 deal with second oscillator harmonic interference appearing on medium wave (500 to 650 kc/s) and long wave (140-300 kc/s) respectively. These last four graphs are all

lines have been drawn in to represent each carrier plus its sidebands, and, where a pair of vertical

Examples of these are as follow

Fig. 3: any i.f. between 345 and 363 kc/s will produce second channel interference on 200 kc/s Light Programme channel from 908 kc/s London Home Service transmitter.

Fig. 4: any i.f. between 337 and 355 kc/s will produce second channel interference on 647 kc/s 3rd Programme channel from 1340 kc/s European Service transmitter.

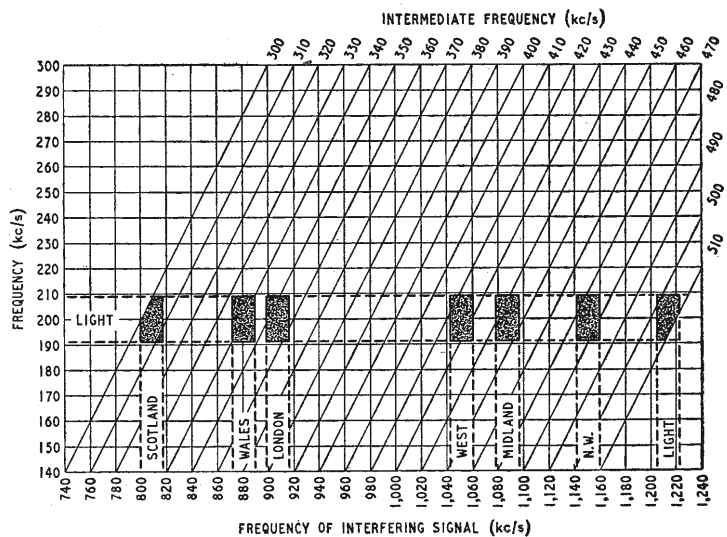

Fig. 3. Second channel interference on l.w. Dotted horizontal lines represent wanted transmitter carrier plus sidebands, dotted vertical lines unwanted signals. Any i.f. cutting across shaded position may be expected to produce interference on wanted station caused by unwanted station to which shaded position refers.

lines cross a pair of horizontal lines, that area has been shaded in. The diagonal lines represent intermediate frequencies plotted at intervals corresponding to 10 kc/s, and, if any of those frequen-

Fig. 5: any i.f. between 300 and 321 kc/s will produce oscillator second harmonic interference on 647 kc/s 3rd Programme channel from 1594 kc/s I.C.F. transmitter. (Although this is hardly likely to

Intermediate Frequency and the Copenhagen Plan—

occur owing to the extremely low power used on this channel, it has been used to illustrate the example).

Fig. 6: any i.f. between 485 and 500 kc/s will produce oscillator second harmonic interference on 200 kc/s Light Programme channel from 881 kc/s Welsh Home Service transmitter.

The results obtained from these graphs were summarized and put into a table as shown in Table II below.

This table should be used in conjunction with the one giving the geographical positions and aerial powers of the transmitters referred to above, as interference between stations can only become serious where the receiver is working in the strong field of the local station (interference source), and the transmitter working on the affected channel is relatively distant.

The startling result mentioned in the first paragraph now becomes apparent. It is, that although an intermediate frequency can be found that will give reasonable freedom from whistles on local stations in any one part of the

country there is no i.f. that will do this for the whole country. Furthermore, this does not take

There are, of course, methods of overcoming this state of affairs: (1) by improved pre-selection,

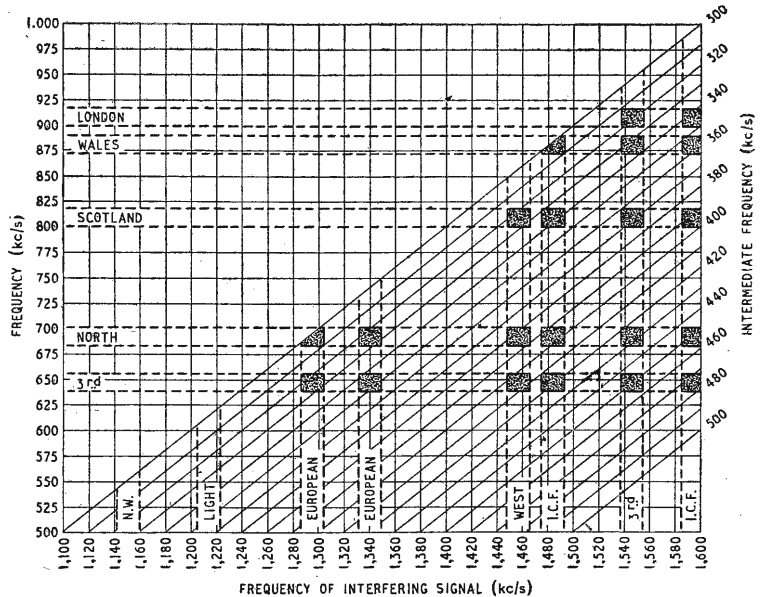

Fig. 4. Second channel interference on m.w. Use as Fig. 3.

into account any interference that might be caused by powerful continental stations close to Great Britain.

(2) by using a higher i.f. (e.g., 2.1 Mc/s) or (3) by breaking away from the superheterodyne and using a t.r.f. or Synchrodyne type of receiver. From a manufacturer's point of view these must all be rejected: (1) because of cost, (2) because the higher i.f. would cause selectivity troubles, making it imperative to use more tuned circuits which would therefore involve higher costs again, and (3) because for many years to come the superheterodyne will be the first favourite of users, on the grounds of its cheapness, sensitivity, selectivity and ease of handling.

A Solution

The writer favours a solution, which unfortunately seems doomed from the start because of all sorts of obscure reasons, such as tradition, prestige, a "status quo" attitude of mind, international agreements and even possibly foreign policy! This solution is, that the Light Programme transmitter be taken off the long waveband and moved to (say) the 647-kc/s channel. One European Service station is moved to take the place of the Light Programme on 200 kc/s, thus leaving a vacant channel on 1295 kc/s, which would

TABLE II

Intermediate Frequencies Eliminated (kc/s)	Channel Affected	Interference Source	Cause
300—305.6	908 kc/s (London)	—	I.F. 3rd harmonic
300—313	200 kc/s (Light)	809 kc/s (Scotland)	2nd channel
300—315	200 kc/s (Light)	692 kc/s (North)	Osc. 2nd harmonic
300—310	692 kc/s (North)	1295 kc/s (European)	2nd channel
310—327	908 kc/s (London)	1546 kc/s (3rd)	2nd channel
319—328	647 kc/s (3rd)	—	I.F. 2nd harmonic
315—333	{ 809 kc/s (Scotland) 647 kc/s (3rd) 692 kc/s (North)	1457 kc/s (West)	2nd channel
323—340	881 kc/s (Wales)	1295 kc/s (European)	2nd channel
332—350	200 kc/s (Light)	1340 kc/s (European)	2nd channel
341.5—350.5	692 kc/s (North)	1546 kc/s (3rd)	2nd channel
337—355	647 kc/s (3rd)	881 kc/s (Wales)	2nd channel
347.6—353.6	1052 kc/s (West)	1340 kc/s (European)	I.F. 2nd harmonic
345—363	200 kc/s (Light)	908 kc/s (London)	2nd channel
359.6—365.6	1088 kc/s (Midland)	—	I.F. 3rd harmonic
359—377	809 kc/s (Scotland)	1546 kc/s (3rd)	2nd channel
373—390	692 kc/s (North)	1457 kc/s (West)	2nd channel
380.6—386.6	1151 kc/s (N.W. and N.I.)	—	I.F. 3rd harmonic
385—430	200 kc/s (Light)	809 kc/s (Scotland)	2nd harmonic
400—409	809 kc/s (Scotland)	—	I.F. 2nd harmonic
395—413	647 kc/s (3rd)	1457 kc/s (West)	2nd channel
401.6—407.6	1214 kc/s (Light)	—	I.F. 3rd harmonic
417—430	692 kc/s (North)	1546 kc/s (3rd)	2nd channel
417—435	200 kc/s (Light)	1151 kc/s (West)	2nd channel
428.6—434.6	1295 kc/s (European)	—	I.F. 3rd harmonic
4—4—445	881 kc/s (Wales)	—	I.F. 2nd harmonic
434—452	200 kc/s (Light)	1088 kc/s (Midland)	2nd channel
443.6—449.6	1340 kc/s (European)	—	I.F. 3rd harmonic
440—458	647 kc/s (3rd)	1546 kc/s (3rd)	2nd channel
449.5—458.6	908 kc/s (London)	—	I.F. 2nd harmonic
455—500	200 kc/s (Light)	881 kc/s (Wales)	Osc. 2nd harmonic
465—485	200 kc/s (Light)	1151 kc/s (N.W. and N.I.)	2nd channel
482.6—488.6	1457 kc/s (West)	—	I.F. 3rd harmonic
485—500	200 kc/s (Light)	908 kc/s (London)	2nd harmonic
491.6—497.6	1484 kc/s (I.C.F.)	—	I.F. 3rd harmonic
497—500	200 kc/s (Light)	1214 kc/s (Light)	2nd channel

make it possible for all the transmitters below this frequency to move progressively upwards: e.g., 3rd Programme to 692 kc/s, Northern Home Service to 809 kc/s, etc. The disadvantage of doing this would be to reduce the non-fading area of the Light Programme transmitter from about 400 miles radius to some 120 miles.

The advantages are well worth consideration; dispensing with home broadcasting on long waves would be a good opportunity to commence a gradual process of elimination of the long waveband from our receivers. This would enable cheap single-waveband receivers to be produced,

any chance of oscillator radiation causing interference with neighbouring receivers. For example, the oscillator of a receiver using an i.f. of 467 kc/s and tuned to 692 kc/s would radiate a signal on 1159 kc/s, so causing an 8-kc/s beat note to be heard on a neighbouring receiver tuned to 1151 kc/s. An i.f. of 475 kc/s would probably be the safest choice. The alternative seems to be the outrageous proposition, which has been made in certain quarters, that receivers should be manufactured with different intermediate frequencies for

668-kc/s Northern Home Service transmitter. The first must be rejected on the grounds that it is obviously not a commercial proposition, and the second because the alternative intermediate frequencies for different areas would probably be too widely separated to be covered by a conventional i.f. transformer. Furthermore, it is hardly desirable that new receivers should be interfered with. Even if these difficulties could be overcome, it would still be a rather awkward process, as a very different i.f. would require different padding condensers in the oscillator circuit; this is too ridiculous to contemplate under mass-production conditions.

The Copenhagen Plan appears to have been based on political expediency, rather than technical necessity, and as such is a failure. Already, seven countries have denounced the Plan, and will therefore not abide by it; seventeen have made reservations regarding it and two have been allocated frequencies without even having representatives at the Conference. It is doubtful whether the Plan can be amended at this late stage, but we should at least try

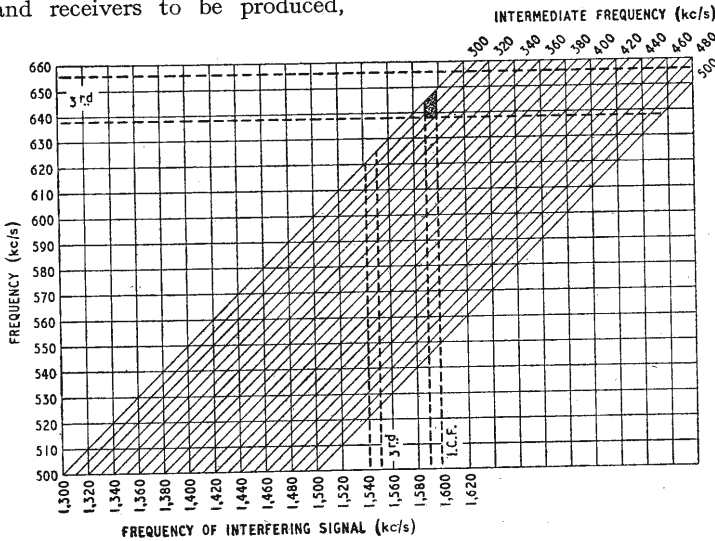

Fig. 5. Oscillator second harmonic interference on m.w. Use as Figs. 3 and 4.

or alternatively the cost saved could be put into making receivers with either improved pre-selection or improved audio stages. The problem of coverage is not insurmountable, as more low-power synchronized transmitters placed at strategic points could make up for any deficiencies. Our broadcasting system has always been based on the 200-kc/s transmitter, but there is no need for it to continue to do so. After all, the Americans have got on very well without the long waves, and they probably get fewer complaints regarding fading than we do.

Should this suggestion be adopted, it would allow any i.f. between 467 and 478 kc/s to be used with confidence, although care should be taken to minimize

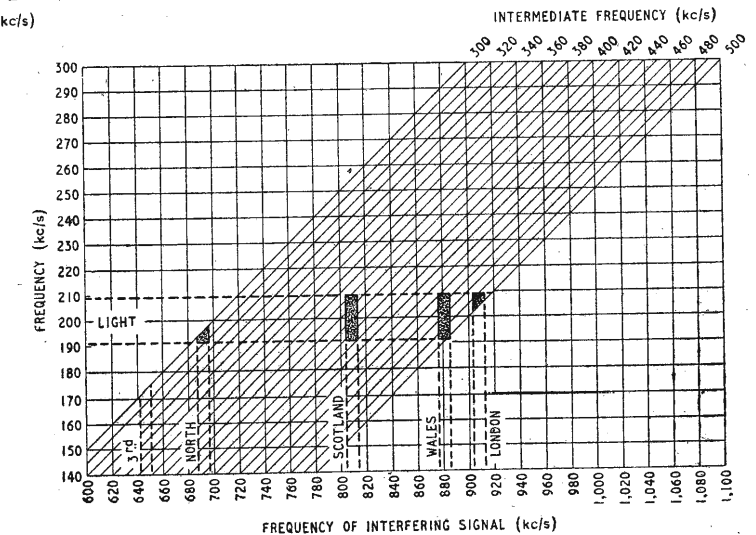

Fig. 6. Oscillator second harmonic interference on l.w. Use as Figs. 3, 4 and 5.

different areas, or that the i.f. should be altered by the retailer concerned, as is done at present in certain areas served by the

to attain as good a broadcasting service in this country as possible, without placing the burden on the manufacturers.

VALVE MEGOHMMETER

Linear Scale : Readings Independent of Battery Voltages

By W. H. CAZALY

MEASUREMENT of resistance to an accuracy of, say, 2 or 3 per cent. over the range of 5,000 ohms to 5 megohms, which includes most of the values met with in radio apparatus, presents certain difficulties that are not satisfactorily overcome in simple self-contained instruments having one or more resistance measuring ranges. There is not room in the cases of such instruments for high-voltage batteries; nor, normally, is the basic indicator sufficiently sensitive to give clear-cut indications of high resistance values over more than half the scale, the shape of which is extremely non-linear. It is true that most resistance values specified are of wide tolerance (e.g. 20%), but occasions are becoming more frequent when close approximations are desirable.

There are three possibilities. One is to employ in a separate ohmmeter the almost standard circuit now in use in most multi-range test instruments, but to incorporate a very sensitive indicator (say a 100 micro-amp. meter) and a battery up to 100 volts. However, the grave objection remains of extreme non-linearity of scale shape, and such an instrument gives only rough indications over the bottom half of the scale—the region of indication of the highest values, which is most needed. A second possibility is to use a bridge. This requires a very sensitive galvanometer for balance indications, and either a very accurate potentiometer of wire-wound high-resistance construction, or an accurate high-resistance box and ratio arms and a fairly high energizing voltage, together with reasonably skilled operation. It is good for laboratory use but is not very suitable for general purpose workshop measurements and fault tracing. The third possibility is to employ a true potentiometer circuit with a high-impedance valve-operated indica-

tor, on the lines of a recent article.*

As will be shown, such an instrument can be designed to have practically linear scale shape, to be very simple to operate, and to be light, portable and easily maintained in good order. The order of accuracy that can be expected is about 2% and is dependent only on the accuracy of construction of the potentiometer circuit; it is independent of energizing voltage variations within wide limits and of changes in valve characteristics. Indication is given by any uncalibrated milliammeter of up to about 2 or 3 mA full scale deflection, or a centre-zero indicator of similar sensitivity.

Potential Divider

Application of the principle involved is shown in basic form in Fig. 1(a). If a voltage V_1 is applied across R_1 and R_2 in series, then

$$\frac{R_2}{R_1 + R_2} = V_2/V_1$$

If the ratio V_2/V_1 is kept con-

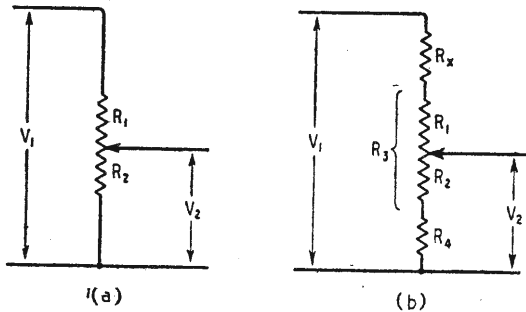

stant, any increase of R_1 must be accompanied by an increase of R_2 . The value of R_2 is thus a measure of the value of R_1 .

In Fig. 1(b), the voltage V_1 is applied across a potentiometer circuit consisting of a resistance under test, R_x , in series with a potentiometer R_3 and a fixed resistance R_4 . The portion of R_3

above the slider is called R_1 and the portion below it R_2 . The ratio V_2/V_1 is a constant, let us call it a . Then

$$\frac{R_2 + R_4}{R_x + R_3 + R_4} = a$$

and

$$R_2 = a(R_x + R_3 + R_4) - R_4 \tag{1}$$

Thus R_2 is a linear function of R_x when a , R_3 and R_4 are constants. When $R_x = 0$ and $R_2 = 0$ —i.e., when the test resistance is zero and the slider on R_3 is at the bottom of R_3 , or the top of R_4 —

$$a(R_3 + R_4) = R_4$$

$$aR_3 = R_4 - aR_4$$

$$R_4(1 - a) = aR_3$$

$$R_4 = \frac{aR_3}{1 - a}$$

Dividing top and bottom of the right-hand side of the equation by a , we have

$$R_4 = \frac{R_3}{1/a - 1} \dots \tag{2}$$

When the slider on R_3 is at the top of R_3 , $R_2 = R_3$. We then have, from (1)

$$R_x = \frac{(R_3 + R_4)(1 - a)}{a} \tag{3}$$

The complete circuit diagram of a practical form of the megohmmeter is given in Fig. 2. A mains-driven version is of course possible; furthermore, the use of alternating energizing voltage opens possibilities of employing

Fig. 1. Basic potentiometer circuit.

the device for the measurement of reactance and impedance as well as resistance. Confining the discussion, however, to the use of the device for measuring high resistance, it is probably more convenient to construct in battery form, unless the instrument is likely to be in very frequent use—as it might be in a service department. Since the h.t. voltage required is from 45 V to 100 V,

* "Electronic Megohmmeters," by H. G. M. Spratt, *Wireless World*, Oct. 1948.

and, by the use of the press switches S_1, S_2 , current is passed only during actual setting up or measurement (and, by this means, cannot be left on inadvertently), it is feasible to make it self-contained and quite portable.

Provision is made for two ranges of measurement, range 1 giving indications of the value of the test resistance R_X between about 50 k Ω and 5 M Ω , and range 2 between 5 k Ω and 0.5 M Ω . By making R_5 a 0.5 M Ω potentiometer, and employing a 5050 Ω fixed resistor in place of R_7 and R_8 , a very high range up to 50 M Ω could be provided. Difficulties in obtaining a potentiometer of 0.5 M Ω with an accurately linear characteristic would have to be overcome. However, the two ranges shown are readily obtained by means of the ganged switches S_4, S_5 , which alter the values of the potentiometer section.

The only components of which the values are critical are R_6, R_7 and R_8 . In the circuit shown, the value of R_5 , on which the others depend, is given as 50 k Ω ; but by the use of equation (2), the value of $R_7 + R_8$ can be calculated for any value of R_5 ; all other resistors can be chosen to within the usual "preferred" 20% tolerance. Nor is the choice of valve very critical; almost any fairly high mutual conductance triode or pentode passing up to a couple of milliamperes with zero grid bias and having a straight I_a/V_g characteristic between 0 and -1V is suitable. The calibration of the milliammeter is unimportant, since it serves only as an indicator of a fixed arbitrary value of anode current. Such wide latitude in the choice of most of the components renders the instrument easy and cheap to construct.

The pilot lamp, which should be rated at 2.5 volts with 0.1 amp. passing (assuming that the valve filament current is 0.1 amp.), serves mainly as a barretter and also very roughly indicates the condition of the l.t. valve filament battery, which here is 4.5 volts and may consist of the usual large 3-cell flash-lamp type. The h.t. battery, if composed of either one or two small 45-volt h.t. battery units such as are used in hearing aids, can be conveniently housed inside the case, rendering the

instrument entirely self-contained. The internal resistance of the battery is not likely to be high enough appreciably to affect indication accuracy, even near the end of its life, but it may be found that as it approaches exhaustion there is a tendency for the indication on the meter to drift; this is seldom likely to be troublesome over at least half the battery life, and its only effect is to make it desirable to reset the instrument for zero R_X from time to time during a series of measurements.

Of the switches, S_3 must be of a type with extremely high open-circuit resistance. It is a press-to-close type and can be made

the grid resistance and capacitance, R_g and C , is partly to reduce erratic noise voltages and partly to avoid heavy grid current if the switches S_1, S_2 and S_3 are inadvertently pressed while the slider of the potentiometer is at the high end of the scale or near it.

Design Procedure

It is possible to calculate the essential circuit constants and ranges obtainable for any special purposes by means of equations (2) and (3). Design starts with the choice of R_5 potentiometer resistance, and of the constant a . The higher the value of R_5 and the lower the ratio a , the higher

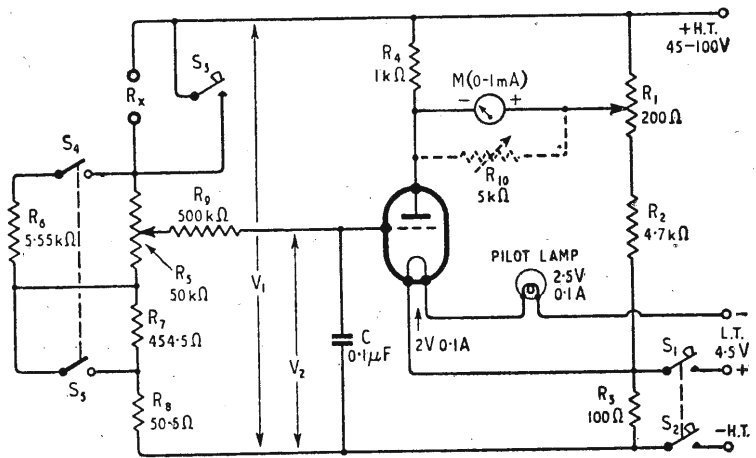

Fig. 2. Circuit diagram of practical instrument with two ranges.

easily enough out of hardened brass strips mounted on some very good insulant such as Perspex, Permalin, etc. The test resistance terminals must themselves be very well insulated. The operation switches S_1 and S_2 are again press-to-close types, ganged, but they need be of no exceptional insulation. S_4, S_5 are normal ganged wafer type switches of good quality, usually obtainable on a single wafer.

The function of the bleeder chain R_1 to R_3 is to provide backing-off voltage for the meter and bias for the valve grid. The values of R_1 and R_3 depend to a large extent on the valve characteristics, but the values shown are typical for a small battery triode. This chain of resistors has to pass about 20 mA with 100 volt h.t., and should therefore be constructed of elements of suitable wattage rating. The function of

the maximum resistance that can be measured. The value of the fixed resistors $R_7 + R_8$ is obtained by using equation (2). The maximum resistance that can be indicated on the scale of the potentiometer is found from equation (3). Then, by dividing the angle of effective rotation of the potentiometer slider by the maximum resistance, the number of degrees per megohm or kilohm can be found and the scale appropriately divided. Such a scale, with a maximum at 5 M Ω , for a potentiometer with a 270° angle of slider rotation—54° per megohm—is shown in Fig. 3.

For example, in Fig. 2, R_5 , corresponding with R_3 in equation (2), is 50 k Ω . The constant a is 1/100. Then, from equation (2), $R_4 = 505 \Omega$. The maximum indicated resistance is found from equation (3) . . . $R_X = 5 \text{ M}\Omega$.

On range 2, which must follow

Valve Megohmmeter—

the same law as range 1 in order to employ the same scale with a $\div 10$ factor, R_5 must be replaced by some value which will keep the ratio α constant at $1/100$. It would be possible to employ change-over switching to bring a second potentiometer of 5000 ohms into circuit to replace the existing R_5 of 50 k Ω . It is simpler, however, to place R_6 in parallel with R_5 , so that the parallel combination of R_5 and R_6 comes to 5000 ohms. Similarly, by making the equivalent of R_4 in equation (2) in the form of the two resistors R_7 and R_8 , of the values shown, the correct ratio of resistances and voltages to make α constant at $1/100$ can be obtained by shorting R_7 ,

Zero Setting and Operation

The function of the indicator is solely to indicate when α the constant ratio V_2/V_1 , is present. This ratio is always present, regardless of the value of the energizing voltage V_1 , when the slider on R_5 is at the bottom, $R_X = 0$, end. Obtaining an indication on the meter M, therefore with the test leads shorted (making $R_X = 0$) and the R_5 slider at the zero end of the scale provides a standard indication on the meter M which shows when the ratio $\alpha = 1/100$ is present. The instrument is set up as follows:—

(1) The potentiometer slider is moved to the zero end of the scale.

(2) Switches S_1 , S_2 and S_3 are simultaneously closed. (These two press switches can be placed close together alongside each other on the panel, so that two adjacent figures can close them simultaneously.)

(3) The slider on R_1 is then adjusted until some convenient deflection—say mid-scale deflection—is shown on the meter M.

S_1 , S_2 and S_3 can then be released and the instrument is ready for use in measurements. The resistance under test is connected across the R_X terminals. Then S_1 , S_2 alone is pressed and R_5 adjusted until the meter indication obtained in operation (3) is obtained.

Discrimination—i.e., the ability of the indicator to show clearly different indications for two adjacent settings of the pointer on

scale—is depended partly on the magnitude of the energizing voltage and partly on the sensitivity of the indicating meter M. The higher the energizing voltage, the greater the volt drop per degree across the potentiometer scale and hence the greater the

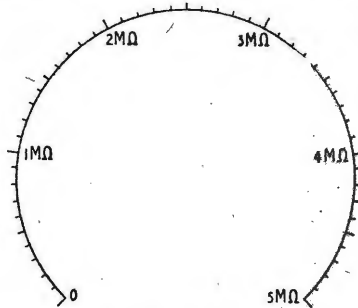

Fig. 3. Typical scale division— 54° per megohm with 270° total rotation.

effect of movements of the pointer in varying grid voltage and hence anode current. A high-slope valve is desirable. The more sensitive the indicating meter M, the more its indications will be affected by changes of grid potential. A $0 - 1$ mA meter is normally satisfactory, but considerably higher accuracy can be obtained by the use of a microammeter with full scale deflection of about $200 \mu\text{A}$. The main disadvantage of using so sensitive an indicator lies in the possibility of damaging it by excessive current due to widely incorrect settings of the backing-off slider on R_1 . This can be avoided by the use of a variable shunt, R_{10} , across the microammeter, which is shown as an optional feature.

**"WILLIAMSON" AMPLIFIER:
NEW VERSION**

THE second part of this article, which deals with the design of a preamplifier and tone compensating circuits, is unavoidably held over until a later issue.

Several readers have enquired about R_{12} (page 284, col. 2 of previous issue). This was a signal balancing potentiometer between R_{11} and R_{13} in the original circuit, to which the notes on signal balancing refer. In the new version the question of signal balancing does not arise.

In the list of components below Fig 1 (p. 282), the values of R_{13} and R_{14} were omitted. In the original design they were each 100Ω , $\frac{1}{2}\text{W}$, $\pm 20\%$.

MOTOR CYCLE RADIO**F.M. Communication Equipment
with Calling Facilities**

A COMPACT v.h.f. radiotelephone weighing under 20 lb and designed for use on a motor cycle, small car or other vehicle, where space, weight and economy of operation are essential qualities, has been introduced by E. K. Cole, Ltd., Southend-on-Sea, Essex. It operates in the 65- to 100-Mc/s band, and like all mobile equipment of this kind is remotely controlled and sends and receives on pre-set spot frequencies using crystal-stabilized transmitter and receiver.

In the case of this new Ekco set (type CE39), special care has been taken to keep the battery consumption as low as possible and this may be one reason for the choice of frequency modulation, as this system avoids the need for relatively high-power modulating equipment. The receiver alone consumes 18 watts, on stand-by with the transmitter valves alight 30 watts, and when transmitting 55 watts with a 6-volt supply and 80 watts with 12 or 24 volts.

The r.f. output is 5 watts with 6-volt operation and 10 watts with 12 or 24 volts. In addition an audio output of about 0.5 watt is available for a small P.A. loud-speaker or intercommunication telephones. Provision is also made for



Ekco mobile f.m. transmitter and receiver fitted to a motor cycle.

calling a fixed station and different tones can be used as a means of identification; these range from 300 to 3,000 c/s.

The range of the equipment is difficult to assess as it is governed by the height of the fixed station aerial and power and to a lesser extent on the location of the mobile unit. A conservative estimate is from 10 to 30 miles.

THE article published in your July issue on "Diversity F.M. Transmission" gives the impression that the scheme described is a direct f.m. equivalent of the multi-carrier a.m. scheme and one which offers certain advantages over it, especially in economy of frequencies. I would suggest that the scheme as described offers no economy of frequency requirement and indeed will occupy more frequency space than the equivalent multi-carrier a.m. system. It has, moreover, a number of important disadvantages rendering it difficult to engineer and incapable of wide application.

The scheme described is a synchronous one and suffers from two important disadvantages common to all synchronous schemes, a.m. or f.m. First, means must be found to synchronize the transmitters and secondly, standing waves are created between the transmitters. By using the multi-carrier a.m. system, synchronism is avoided and the fields from the different transmitters assist each other. Inherently better coverage is therefore obtained. It is pertinent to observe that in attempting to engineer multi-station f.m. schemes, synchronism is not employed from choice but because multi-carrier f.m. is impracticable.

Interaction

The article implies that interaction due to standing waves was negligible over the route chosen for test. Under the conditions described this is only to be expected. The area under test was a heavily built-up one (London). The three stations were sited almost in a straight line. Further, high ground exists between the master station and each satellite. I can imagine few sets of conditions less likely to show the effects of standing waves between synchronized v.h.f. transmitters. The results over open country, river, sea and in the air are likely to be very different. In this connection it should be pointed out that in testing the multi-carrier a.m. system, care was taken to select areas where interaction would be typical of maximum.

It was also unfortunate that the demonstration should have de-

DIVERSE VIEWS ON "DIVERSITY"

New Aspects of the F.M./A.M. Controversy

ended on so simple and so convenient, but in practice so unlikely, a relationship as 3 to 2 between link and carrier frequencies. The Home Office is the only authority in this country to be favoured by the provision of radio frequencies for links between fixed stations in a multi-station scheme. So long as the G.P.O. maintain their present policy in this direction, the majority of multi-station schemes in this country will have to employ telephone line linkage. The f.m. scheme described would, of course, be quite impracticable on such a basis. There is no known f.m. equivalent, for example, to the multi-carrier a.m. schemes now being installed by the Ministry of Civil Aviation using line linkage.

Even to users such as the Home Office, who use radio linkage, a 3 to 2 relationship would be quite impracticable since to synchronize carriers in the range 95-100 Mc/s a linkage band 7.5 Mc/s wide would be required. By using a.m. throughout, linkage is practicable in a band only 1 Mc/s wide.

It may be argued that by employing many other multiplication factors the 7.5 Mc/s band could be reduced. I, for one, would have to be convinced that this would not lead to very involved electrical multiplication systems, different for every scheme and inflexible to alteration of frequency. It would also lead to very low crystal frequencies with the attendant danger of spurious radiation from unwanted crystal harmonics.

The article also implies that because two particular a.m. multi-carrier schemes used more frequencies than the f.m. scheme described, the latter offers economy in frequency allocation. Both these a.m. schemes, however, gave additional facilities not provided by the f.m. scheme. The

first had an additional link from the control point to the master station and the second gave duplex facilities. In any case, merely counting carrier frequencies used does not assess the merits of a scheme in this direction. For example, the G.P.O. allocate two frequencies (one sending, one receiving) to many schemes where a single frequency would serve, because an overall economy results from double-frequency allocation.

Bandwidth Requirements

An a.m. scheme to perform an equivalent function to the f.m. scheme described would use the same number of link frequencies. It could equally well use the same channel for transmission to and from mobiles. A three-station a.m. scheme need use no more bandwidth for the channel transmitting to the mobiles and could use less channel width on the links and on the channel from the mobiles. Even on the outgoing channel the f.m. scheme will radiate sidebands to approximately ± 15 kc/s from all three stations. From every aspect, therefore, the f.m. scheme radiates more *total* ether disturbance than the a.m. scheme.

I, therefore, conclude that the f.m. scheme described is inferior to a multi-carrier a.m. scheme in the following respects. First, since it is a synchronous scheme it creates standing wave patterns between transmitters which must degrade coverage. Second, it has not provided a simple and flexible means of achieving synchronism. Third, it uses more total bandwidth than is required by multi-carrier a.m. scheme. While not wishing to discredit the work of the engineers who were responsible for the demonstration, it appears to me that a great deal of trouble has been taken in an

"Diverse Views on Diversity"—attempt to use f.m. to achieve an object which is more satisfactorily and more simply obtainable by a.m. J. R. BRINKLEY (Pye Radio Works, Cambridge).

F.M. SPONSORS' REPLY

WITH reference to J. R. Brinkley's communication discussing various points raised with regard to your recent article on diversity f.m. transmission, it would appear that he has not appreciated that the demonstrations you described were primarily aimed at evaluating the importance of the standing wave patterns which must be created when two or more transmitters operate on identical frequencies.

In reference to his suggestion that the conditions were particularly unfavourable for showing the effect of standing waves, it should be clear that wherever there is continuous coverage between two transmitters, standing waves exist. The results in the tests witnessed were no different from those encountered when similar transmitters have been installed in other areas, including more open country, and during the tests demonstrations were carried out in the areas of equal signal

strength where any effects would be at their maximum. It is not claimed that standing waves are not likely to occur but simply that the small amount of distortion which can be detected is not important, and the number of technical people witnessing the demonstration appeared to agree with this.

With regard to the efficient use of the frequency spectrum, only two points appear to arise. First, that in the system demonstrated the frequency spectrum used for the main transmissions to cars is not more than that required for the operation of a single transmitter, and that the receiver bandwidth need only be such as to receive a single transmission and, therefore, give the best possible signal-to-noise ratio at all times while leaving adjacent channels free for other services.

Secondly, in all cases where a radio link is required between the main station and its satellites, this link simultaneously provides the synchronised signal and the required modulation. In such circumstances only a minimum number of operated frequencies would appear to be involved.

N. R. BLIGH
G.E.C. Research Laboratories,
Wembley.

SHORT-WAVE CONDITIONS

July in Retrospect: Forecast for September

By T. W. BENNINGTON and L. J. PRECHNER (Engineering Division, B.B.C.)

DURING July the average maximum usable frequencies for these latitudes were slightly lower than during June, both by day and by night. Daytime working frequencies were therefore relatively low—except for north/south paths—and those for night-time relatively high. Daytime communication in the 28-Mc/s band was, for example, very infrequent, except on a few southerly circuits. At night the use of frequencies below about 11 Mc/s was seldom necessary.

The average sunspot activity, which, since 1947, has been fluctuating slightly about a very high value, is now showing a more decided tendency to decrease, so it may be anticipated, though not with complete confidence, that generally lower frequencies will be workable during the coming autumn and winter than was the case during those seasons last year.

During July a very considerable amount of Sporadic E occurred, and medium-distance communication on very high frequencies by way of this medium was frequently possible.

July was an exceptionally "quiet" month, and only two ionospheric storms of minor intensity occurred (during the periods 13th/14th and 17th/19th). "Delinger" fadeouts were reported as occurring at 0635 on 11th, 0919 on 25th, 1227 on 27th, 1120 on 28th, 1415 on 29th, 0730 on 30th, and 0830 and 1507 on 31st.

Long-range tropospheric propagation does not appear to have been so prevalent as might have been expected having regard to the anticyclonic weather conditions which prevailed during most of the month, though some of it did occur occasionally.

Forecast.—During September the Northern Hemisphere seasonal

effect will tend to cause a considerable increase in the daytime m.u.f.s, though this may be somewhat modified by the decrease in sunspot activity. On the whole it may be anticipated that daytime m.u.f.s will be appreciably higher and night-time m.u.f.s considerably lower, than during August.

Working frequencies for long-distance transmission paths should therefore be relatively high by day, and the higher frequencies—like 28 Mc/s—should be usable in most directions from this country. Night-time working frequencies should be such that 11 Mc/s will be about the highest usable for regular communication and considerably lower ones will be necessary on some circuits. For distances up to about 1,800 miles the E and F₁ layers should continue to control transmission for a few hours around noon only.

Sporadic E is likely to occur less often, though some medium-distance communication on high frequencies may still be effected by way of this medium.

Below are given, in terms of the broadcast bands, the working frequencies which should be regularly usable during September for four long-distance circuits, running in different directions from this country. (All times in this report are G.M.T.) In addition, a figure in brackets indicates the highest frequency likely to be usable for about 25 per cent of the time.

Montreal :	0000	11Mc/s	(16Mc/s)
	0100	9 "	(13 ")
	0900	11 "	(16 ")
	1000	15 "	(20 ")
	1200	17 "	(25 ")
	2100	15 "	(19 ")
	2300	11 "	(17 ")
Buenos Aires :	0000	11Mc/s	(16Mc/s)
	0800	15 " or 17Mc/s	(21 ")
	1000	21 "	(30 ")
	1500	26 "	(34 ")
	1800	21 "	(30 ")
	2000	17 "	(24 ")
	2200	15 "	(22 ")
2300	11 "	(20 ")	
Cape Town :	0000	11Mc/s	(18Mc/s)
	0500	17 "	(22 ")
	0600	21 "	(30 ")
	0800	26 "	(36 ")
	1600	21 "	(30 ")
	2000	17 "	(23 ")
	2200	15 "	(20 ")
Chungking:	0000	7Mc/s	(13Mc/s)
	0100	9 "	(14 ")
	0300	11 " or 15Mc/s	(17 ")
	0500	17 "	(27 ")
	1600	15 "	(22 ")
	1800	11 "	(16 ")
	2100	9 "	(14 ")
2300	7 "	(13 ")	

There is usually an increase in the amount of ionospheric storminess during September, and periods of poor short-wave communication must be anticipated. At the time of writing it would appear that disturbances are most likely to occur during the periods 5th/6th, 9th/11th, and 26th/27th.

IR5
Heptode Frequency
Changer

IS4
Battery Beam Tetrode

IS5
Battery Diode Pentode

3S4
Battery Beam Tetrode

IT4
Battery Pent. Vari-Mu

3V4
Battery Beam Tetrode

Type Number	Application	Heater		Anode Voltage Normal	Screen Voltage Normal	Grid Voltage Normal	Anode Current mA	Screen Current mA	Impedance Ohms	Mutual Conductance mA/V	Optimum Load Ohms	Power Output Watts
		Volts	Amps.									
IL4	Batt. R.F. Pentode	1.4	0.05	90	67.5	0	2.9	1.2	600,000	0.925	—	—
IT4	Batt. Pent. Vari-Mu	1.4	0.05	90	67.5	0/-16	3.5	1.4	500,000	0.9	—	—
IR5	Heptode F.C.	1.4	0.05	90	67.5	0/-14	1.6	3.2	600,000	300*	—	—
IS4	Batt. Beam Tetrode	1.4	0.1	90	67.5	-7	7.4	1.4	100,000	1.58	8000	0.27
IS5	Batt. Diode Pentode	1.4	0.05	90	67.5	0	1.6	0.4	600,000	0.63	—	—
3S4	Batt. Beam Tetrode	1.4 2.8	0.1 0.05	90	67.5	-7	7.4	1.4	100,000	1.58	8000	0.27
3V4	Batt. Beam Tetrode	1.4 2.8	0.1 0.05	90	90	-4.5	9.5	2.1	100,000	2.15	10000	0.27

* Conversion Conductance in Micromhos.

THIS popular range of Brimar Battery Miniatures is suitable for all modern battery operated receivers.

Full details of their characteristics are shown in the table above.

BRIMAR
BATTERY MINIATURES

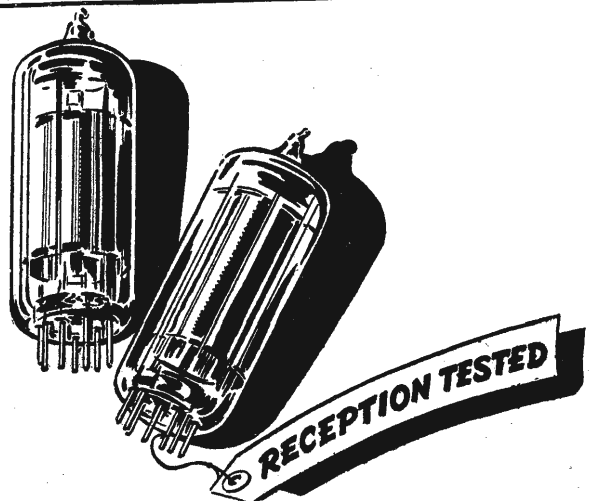

STANDARD TELEPHONES AND CABLES LIMITED, FOOTSCRAY, SIDCUP, KENT.

CRYSTAL PICK-UP PREJUDICES

—their Rhyme and Reason . . .

PREJUDICES are frequently unreasonable, often enough they are formed not from experience but from hearsay. The reputation of Crystal pick-ups has suffered in this way, yet every day and any day there are many thousands of Crystal pick-ups giving delight to gramophone enthusiasts, particularly those who are "sound purists." Then why this prejudice in other quarters? Let us be frank. *Under certain circumstances* Crystal pick-ups have in the past possessed some failings, but, let us hasten to add, failings small enough to be discounted by the user who sought the finest yet obtainable in sound reproduction.

Now, when Radiolympia is about to show us the great strides that ACOS research has made in utilising the amazing characteristics of the piezo-electric principle, it is opportune to review the reasons for the prejudices which persist from the pre-ACOS era.

The fallacy of their fragility

First, there is the belief that the Crystal pick-ups must necessarily be fragile and easily damaged. True, certain early types were easily fractured because assembly methods were as yet unperfected. But the Cosmocord laboratories produced an unbreakable crystal assembly which ensures that NO crystal in an ACOS pick-up can be broken, even by so drastic a measure as tapping the needle with a hammer—an extreme of violence which would never be approached in ordinary usage.

Humidity deterioration effects defeated

A second persistent prejudice against Crystal pick-ups is that the crystal element—Rochelle-Salt—is susceptible to deterioration when subjected to the higher degrees of humidity. Since this failing is an inherent characteristic of Rochelle-Salt, counter measures had necessarily to be those of *protection*. ACOS research was indeed set a formidable problem, the solution of which was particularly elusive, for in

this country the humidity count is much higher than, say, in the United States, where Crystal pick-ups are in almost universal use. Nevertheless the problem was solved by long and intensive research in the Cosmocord laboratories. Now an assembly has been designed which positively counteracts any danger of deterioration from humidity. In this assembly the crystal is mounted in a gel-like substance which provides a complete water-vapour barrier, rendering the cartridge absolutely non-hygroscopic.

Equaliser Circuits now past history

Another criticism is that the Crystal pick-up requires the fitting of an equaliser before satisfactory reproduction can be obtained from the ordinary commercial "constant velocity" records. In passing it should be mentioned that this condition is not confined to Crystal pick-ups only. The criticism is then that in order to attain the best from a crystal pick-up it is necessary to spend time and money on fitting additional components. The connoisseur of sound reproduction has con-

sidered this effort well justified by the results, knowing that a crystal pick-up alone is capable of giving him the high quality he demands.

Now, however, even the critical requirements of the connoisseur can be met without recourse to an equaliser circuit for again ACOS research has solved the problem in providing a crystal pick-up which, without additional components, can be connected direct to any domestic radio set or amplifier.

An invitation to the critics

Thus all past criticisms have been met, and any lingering prejudices shown to be without reason. And in confirmation there is to be inspected *and heard* at the Cosmocord Stand No. 7 and Demonstration Room No. D.10 the latest product from the Cosmocord Research laboratories—a Crystal pick-up of revolutionary design which, apart from providing a new and higher standard of performance, is also a thing of beauty. This pick-up will be available through the Trade after Radiolympia.

See and hear the new

ACOS G.P.20 MICRO-CELL PICK-UP at RADIOLYMPIA

STAND NO. 7. DEMONSTRATION ROOM D. 10.

- Has output 5 to 20 times greater than that of any comparable magnetic type.
- No equaliser components required. Can be connected direct to any domestic radio or amplifier.
- Has unbreakable Crystal element.
- Is unaffected by conditions of extreme humidity.
- No needle talk.
- Record wear virtually eliminated.
- Has provision for interchangeable clip-on head for long playing records. One instrument for ALL records.



COSMOCORD LIMITED • ENFIELD • MIDDLESEX

AUDIO SIGNAL GENERATOR

Auxiliary Circuits : Frequency Calibration

By M. G. SCROGGIE, B.Sc., M.I.E.E.

(Concluded from page 297 of previous issue)

IN the first part of this article the design of the basic oscillator and output stage were discussed. It should have been mentioned that valves V1 to V8 in Fig. 1 are all of type VR65 (Mazda SP6r).

We now turn to the optional refinements.

Attenuators.—Some reduction of voltage is necessary between V2 and V5, so, making a virtue of necessity, part of the potential divider used for this purpose (R_{19}) is calibrated in db to fill in the steps of the switched attenuators in the output. The rest of the divider consists of R_{18} and R_{20} , the latter being variable in order to set the output to the reference level with all the attenuators at zero. To prevent loss of top frequencies it is most important to minimize capacitance to earth from the whole of this input circuit. A great improvement was made by substituting a suspended tubular C_{10} for one of the earthed metal case type.

To maintain optimum output conditions, the attenuators following V5 must at all settings appear to V5 as a resistance of $5k\Omega$ when a load of that magnitude is connected. V5, when directly connected, appears to the load as a low resistance, of the order of 150Ω . To maintain a constant output resistance (say $5k\Omega$) it would be necessary to use a T attenuator and to accept at least 6 db minimum insertion loss. If one does not insist on a constant output resistance it is possible to use a two-element attenuator (Γ or Γ') and have zero insertion loss. Of these, the Γ type is the more convenient, because its resistances are lower. The values are given in Fig. 6 for two 5-position attenuators, one in steps of 5 db and the other in steps of 20 db. It was calculated that Ayrton-Perry winding was unnecessary, and the

resistors were all wound straightforwardly in groups on $1/32$ in. Paxolin "cards" with 46 s.w.g. Eureka for all over 300Ω , and waxed. Control is by a pair of 2-pole 5-way Yaxley type switches.

With any attenuator, there is an error if the actual load impedance differs from that for which it was designed. With types giving a constant impedance in both directions, the error depends only on the ratio between actual and designed load impedance, but with the type shown here it depends also on attenuator setting.

tract to $\log_{10} \delta$ db. In general a low load resistance draws more power than indicated by the attenuator settings, and *vice versa*. It must be borne in mind that a low load resistance *without* attenuation causes abnormally large distortion.

The relationship with reactive loads differs considerably; one example is given in Fig. 7.

To ensure correct termination when only voltage output is required, an internal $5k\Omega$ resistor (R_{28}) is provided, brought into circuit by S_8 , which also has a position for cutting off the signal. The ratio of the voltage across an external load to that across this $5k\Omega$ can be used, with the help of Fig. 7, to deduce the a.f.

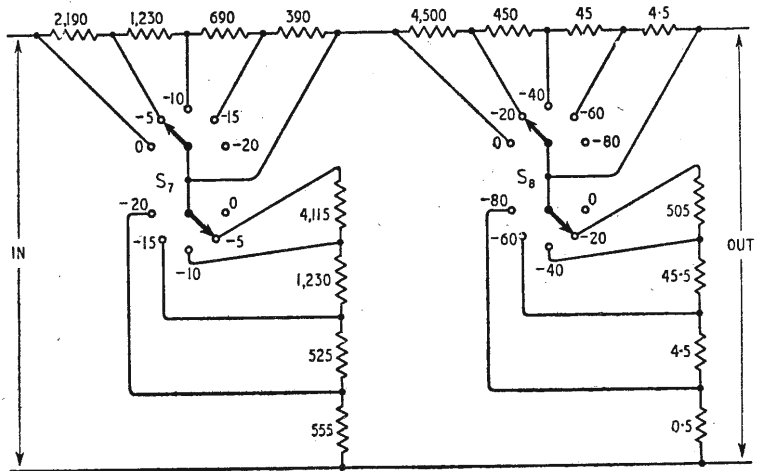

Fig. 6. Diagram of switched attenuators, with resistance values in ohms for $5k\Omega$ load.

Error curves for resistive loads are given in Fig. 7, from which it can be seen that the range of load resistance within which the attenuation is reasonably accurate increases with the attenuation, and for the largest values includes all but very low load resistances. It is important to note that these error curves apply to *voltage* output—the generator is used mainly for voltage rather than power. To convert to power it is necessary to sub-

resistance of the load, so long as it is non-reactive. The most advantageous setting of the attenuator switch for this test is of course 5 db. (Incidentally, it can be shown that the maximum error—voltage ratio—with this type of attenuator occurs at 6 db). A terminal at point B in Fig. 1 would provide a monitor output at unamplified oscilloscope level when using the stepped attenuator.

Antiphase Output.—The second

Audio Signal Generator—

output stage, V7, is identical with the first, except that it has no switched attenuation, but of course it is subject along with the first to the 0.5 db input control. Its drive is provided

to be level up to perhaps 0.5 Mc/s or so. This would be inconvenient and quite unnecessary for audio work. The main requirement is a wavefront not exceeding a few microseconds, and a flat top that does not droop apprecia-

by connecting a capacitor across R₁₂, the value depending on the inequality desired. It works by developing additional bias for V3.

Fig. 8 shows the waveforms obtained at several frequencies. **Valve Voltmeter.**—For stability of calibration combined with simplicity, a modified reflex circuit is used (V8). The meter was a war surplus 0.75 mA instrument; but a 0.5 or 1 mA meter could be used, with some adjustment of R₃₈ and R₃₉ values. For a given setting of R₃₈ there is a value of R₃₉ at which the meter reading anywhere on its scale is not appreciably affected by the largest departures from normal anode voltage that could occur in practice. These two resistances were varied until full-scale deflection was obtained for 28V peak; i.e., reference-level voltage (20V peak) plus 3 db. R₃₉, not being at all critical, was then fixed; but a pre-set R₃₉ was fitted to provide for readjustment of the calibration. Adequate capacitance at C₁₄ is essential for avoiding error at low frequencies.

This type of valve voltmeter gives a nearly linear scale, but its readings are not proportional to mean values—they are somewhere between r.m.s. and peak. It is convenient to calibrate it

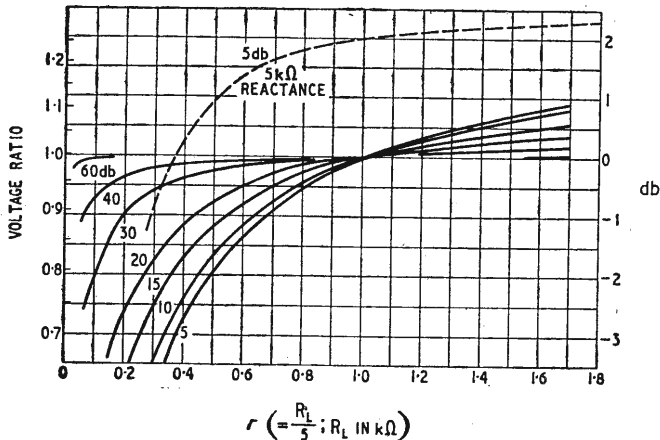

Fig. 7. Curves showing attenuation errors when load resistance is not 5kΩ. The curves correspond to settings of the attenuator switches, and the left-hand vertical scale is in ratio of actual output voltage to output voltage with 5kΩ. The right-hand scale is in db for convenience, to avoid the need for calculating voltage ratios, but it must be realized that the db readings represent voltage ratios and not true power db. To get the latter, it is necessary to subtract $10 \log_{10} r$.

by a floating paraphase stage (V6) tapped to a point on the chain R₂₄, R₂₅, R₂₆ suspended between the two outputs. By adjusting the balancing control (R₂₅) the two output voltages can be made equal and opposite with respect to earth, as required for driving push-pull stages, 1:1 bridges, etc. Not only so, but any desired output ratio, up to 100,000:1, can be obtained by means of the switched attenuators.

The possibility of both outputs being open-circuited at the same time (which would leave the grid of V6 free) is eliminated by R₂₇.

Square.—This consists of two overdriven stages, V3 and V4, which can be interposed between V2 and V5 by means of S₂. To make the square waves equal in amplitude to the sine waves (on a peak, r.m.s., or any other basis) a pre-set control (R₁₇) has been provided.

To maintain a sharply square waveform up to 20,000 c/s it would be necessary for all the circuits (including those of V6)

bly even at 20 c/s. The enormous coupling capacitances that would be needed to achieve the latter by straightforward methods are economically avoided by a compensating capacitor (C₉) in the lower limb of the input potential divider to V5. The value was chosen to bring the wave tops quite level in the normal 5kΩ load. Such a waveform will easily show up low-frequency attenuation even down to 1 c/s.

To achieve a steep wavefront, care must be taken to minimize stray capacitances, especially in the higher impedance circuits. The corners can be sharpened considerably by the use of C₇. Too high a value causes overshoot.

The circuit as shown generates square waves in which the positive and negative half-cycles are slightly unequal—sufficiently to show which is which on the oscilloscope. If they are made very unequal there is a large shift of mean level due to a.c. couplings. On the other hand, a very unequal waveform is an even more searching low-frequency test and may be preferred. If so, it can be obtained

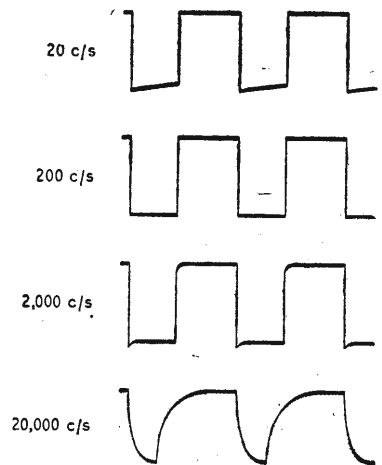

Fig. 8. Square-wave output waveforms obtained at various frequencies.

in r.m.s. or peak values with sine waveform so long as it is remembered that they do not apply with other waveforms. With R₁₇ set to make the square waves equal

in peak-to-peak value to the sine waves, the readings are about 20% greater with symmetrical square waves. If the positive half-cycles are longer, they are less in amplitude than the negative half-cycles, and the voltmeter reading is less.

In addition to the voltage scale, a db scale has been inscribed. Among other uses it facilitates the checking of voltmeter and attenuators against one another.

Power Supply—The entirely conventional system, providing 40 mA at 250V and 4.5A a.c. at 6.3V, is exactly as it was found in Test Set Type 87.

Frequency Calibration.—It must be admitted that a frequency bridge was used for the calibration, but although convenient it is by no means essential, and in any case it was checked by the method to be described. This is the well-known oscilloscope method, in which one standard of frequency is needed. If care is taken to avoid periods during which the demand for electricity is heavy, the 50-c/s time-controlled mains can be used as a reasonably accurate standard. (The Third Programme 440 c/s tuning note at 5.55 p.m. does not allow much time for calibrating but is an extremely accurate check.) With the time base synchronized with the mains, the generator settings giving multiples of 50 c/s can be noted; also without much difficulty, multiples of 25 c/s. When the number of cycles becomes too great to be reliably counted, the generator frequency is kept constant and the time base speeded up until only one generator cycle is visible; the process can then start afresh, but of course it is necessary to make sure that the time-base frequency does not drift. This can be checked with a double-beam instrument, by keeping the 50 c/s sub-multiple pattern on the other beam; or, less conveniently with a single-beam, switching back to it occasionally.

By shifting the ratio of 50 c/s to time-base frequency, further ranges of scale points can be noted on the scale. In general, however, calibration points will not form a convenient scale; and to convert them to the latter the method described by Rendall and Peachey of the B.B.C. in

Wireless Engineer, Feb. 1948, p. 43, can be recommended. According to this, the observed points are pencilled temporarily on the dial, which is then detached and rolled along one axis of a sufficiently large piece of graph paper. As each pencil mark comes against the paper a corresponding mark is made on the axis. To make sure the dial has not slipped during its roll it should be rolled back again, and the coincidence of all the marks checked. A

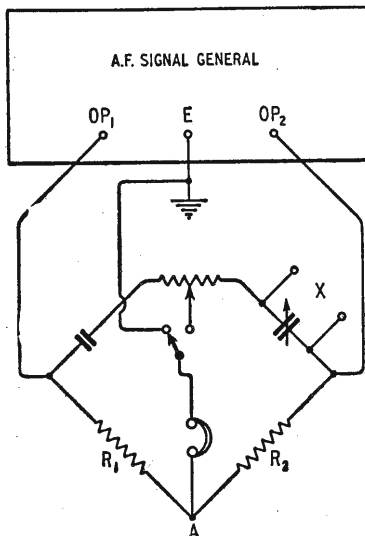

Fig. 9. Method of connecting generator to a typical bridge, for obtaining the benefits of a Wagner earth.

frequency scale is then marked along the other axis, preferably logarithmic, and a graph drawn connecting this scale with the marked frequencies on the first axis. This graph can then be used to find the points on the dial corresponding to the wanted scale markings; they are transferred to it by another rolling operation, after any of the original markings that are not wanted have been rubbed off. The scale is then marked in properly.

This process is particularly worth-while with resistance control, because the resistance element is unlikely to be perfectly regular; as a matter of fact the "Reliance" potentiometers were obviously wound in three stages giving a slightly wavy calibration curve: if the scale subdivisions had been marked in by eye they would have been appreciably in-

accurate near the two winding change-over points.

Finally it is as well to check the scale against the standard when the dial has been replaced.

The slow-motion dial found on the Test Set 87 is rather on the small side (3in. dia.) but is very convenient for the foregoing procedure, as it has a central boss removed by undoing three screws, which can be used to hold a disk cut out of Bristol board, covering up the original calibration and suitable for taking the new one.

If no suitable dial is available, a large pointer rotating over a fixed scale is quite effective.

Before proceeding to fill in the scale it is of course desirable to make sure that the desired ranges are covered, and, if not, to adjust the capacitor values accordingly. It is such a great convenience to have a single frequency scale, with decimal multipliers, that it is worth while taking some trouble to get the capacitances just right. In the present instrument C_{1b} and C_{2b} were first selected to give a 200-2,000 c/s scale with approximately equal margins above and below. This was the range on which the scale was subsequently calibrated fully. As no nominal $0.1\mu\text{F}$ capacitors at hand happened to make the 20-200 c/s range exactly fit this scale, one of them was chosen with a slightly lower capacitance, and the frequency adjusted exactly by fitting a small supplementary capacitor in parallel. For the highest range, a preset trimmer was used for the final adjustment.

Thanks to the care taken to preserve uniform frequency and phase characteristics in the amplifier, the frequency scale drawn for one range fitted the other two without appreciable error at any point.

Use as a Bridge Source.—It is a great convenience if a bridge detector is at earth potential, for then "head effects" or their equivalent with amplifiers or vibration galvanometers are avoided. But both source terminals are necessarily "live." This can easily be arranged with the two-phase output, as shown in Fig. 9. Note that the signal generator is earthed, but not the bridge. The point A can be brought to earth potential, however, by making the voltages from OP1

Audio Signal Generator— and OP₂ have the same ratio as R₁ and R₂. This can easily be done by switching the detector over to earth and adjusting the balancing control and (if R₁ and R₂ are not 1 : 1) the attenuator switches. Final balance exists when nulls are obtained at both

positions of the detector switch. For perfect "earthing" it may be necessary to provide capacitance from earth to either OP₁ or OP₂; but with ratio arms of the same kind this is unlikely to be needed.

The leads from OP₁ and OP₂ should be short and preferably

enclosed in earthed screens up to the bridge arms.

In a substitution type of capacitance bridge, as shown, without any elaborate precautions, it was found that an added capacitance of 300pF to earth from any of the bridge arms affected the answer by less than 1pF.

DUAL CONCENTRIC LOUDSPEAKER

Combined Direct Radiator and Horn Loading

THIS design, which was first shown by Tannoy at Radio-lympia in 1947, is now in production and is being distributed by Sound Rentals, Ltd., Canterbury Grove, London, S.E.27. It consists of a low-frequency direct-radiating cone diaphragm which functions also as the flare for a horn-loaded high-frequency pressure unit. Together these elements cover a frequency range of 25-20,000 c/s. Separate moving-coil drives are arranged at each end of the centre pole of a ring-type permanent magnet of anisotropic material, and the centre pole is bored to form the throat of the h.f. horn.

A cross-over frequency of 1,000 c/s has been chosen and the filter network gives an attenuation of 12 db/octave on each side of this frequency. Since the low-frequency diaphragm is capable of giving adequate output up to 1,000 c/s as a piston and need not rely on "break-up" for higher frequencies, a much heavier material can be used with consequent improvement in the smoothness of response up to that frequency. Attention has also been given to damping at the periphery

to prevent reflection and the setting up of standing waves at any frequency. A four-layer voice coil of low d.c. resistance in a gap flux density of 12,000 gauss ensures adequate magnetic damping, and it is claimed that the system is virtually aperiodic. Actually the product of flux density and conductor length is higher in the l.f. unit than in the h.f., though the latter works in a shorter

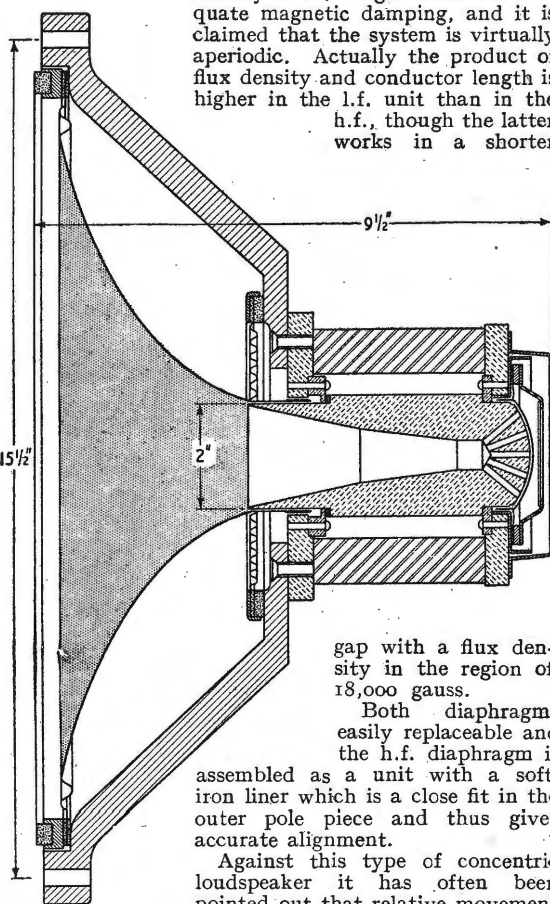

gap with a flux density in the region of 18,000 gauss.

Both diaphragms easily replaceable and the h.f. diaphragm is assembled as a unit with a soft-iron liner which is a close fit in the outer pole piece and thus gives accurate alignment.

Against this type of concentric loudspeaker it has often been pointed out that relative movement between the two sections of the h.f. horn could give rise to intermodulation between low and high frequencies. The makers have carried out two-tone tests to investigate this criticism and find that intermodulation products are less than 2%. We have heard the loud-

speaker in operation and can confirm that, subjectively, intermodulation effects are negligible. There is, in fact, far less blurring in orchestral music than in many single-element loudspeakers with comparable amplitude/frequency characteristics. Attack is good and the transient response generally sup-



Tannoy "Dual Concentric" loudspeaker, and section showing arrangement of horn pressure unit and low-frequency curved-sided diaphragm.

ports the makers' claims of aperiodicity. In a wide variety of test records reproduction was of a very high standard, the only possible criticism being that in one case the high notes of a solo violin were inclined to be metallic, though this might well have been a fault of the recording.

We would not hesitate to put this loudspeaker among the best half-dozen high-quality types from which it is always difficult to make a final choice. One point in its favour is that, in production, the characteristics should be reasonably uniformly maintained, since the design does not rely on subsidiary diaphragm resonances, which are always difficult to repeat.

The price of the unit, which weighs 30lb complete with cross-over network and output transformer, is £26 5s. It is also available in a vented corner cabinet at £52 10s.

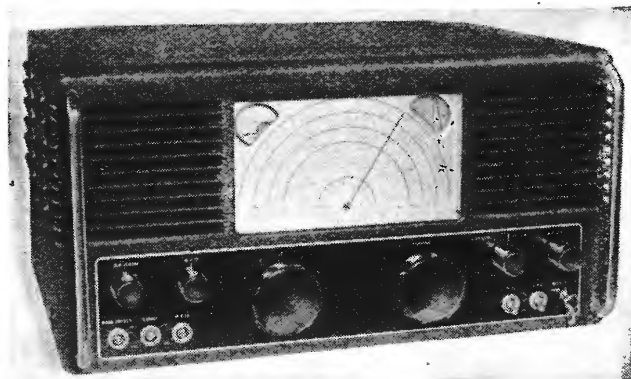

TEST REPORT

**EDDYSTONE
MODEL 680**

The Model 680 has its essential controls neatly and conveniently arranged. Note the large turning knob with one of similar size for the wave-change switch.

The selectivity is changed in steps, five in all, and these give bandwidths of 15 kc/s, 7 kc/s, 4.5 kc/s, 2.5 kc/s and a few hundred c/s respectively, for an attenuation of 6 db at the boundaries. The narrowest of all is with a quartz crystal filter.

Fifteen-valve Super-heterodyne of Advanced Design

THOUGH intended primarily for the exacting needs of professional communications this set possesses an indefinable quality that cannot fail to appeal to the discriminating amateur who is looking for a really sound general-purpose receiver. Neither in conception, nor in coverage, nor in cost is the set in the least "amateurish" and its specification will bear comparison with that of any other set designed for a similar purpose.

It has 15 valves, all but two of which are the latest miniature all-glass type with B7G bases. The frequency coverage is very wide, but perhaps not quite so extensive as some of the sets in the same class because it does not take in the longer wavelengths, necessary for some kinds of professional communications. The frequency coverage of the Model 680 is 480 kc/s (625 m) to 30 Mc/s (10 m) so that it just takes in the 600-metre band which is used extensively for short and medium distance ship-to-shore traffic.

This frequency band is covered by five switched ranges, their individual coverages being 480 to 1120 kc/s, 1.12 to 2.5 Mc/s, 2.5 to 5.8 Mc/s, 5.5 Mc/s to 13 Mc/s and 13 to 30 Mc/s respectively. Although not apparent there is an overlap between all ranges, as the calibrated portions do not in all cases occupy the full length of the scale.

An unusual feature of this set

is that it has a mechanically operated selectivity system, or as it is sometimes called, bandwidth control. The couplings between primaries and secondaries of the i.f. transformers, and hence the selectivity of the circuits, is varied by change in physical relationship of the coils. The principle is not new; it may actually have predated the more commonly used electrical systems, but it is nevertheless a perfectly sound one, and moreover, is quite satisfactory as applied to this set.

attenuation of 6 db at the boundaries. The narrowest of all is with a quartz crystal filter.

In common with all modern high-performance receivers, the Model 680 is a superheterodyne and it has two r.f. stages before the mixer. Their main purpose is not necessarily to improve the sensitivity but to give adequate second-channel rejection at the higher frequencies. Coils with adjustable dust cores are used on all ranges in this portion of the set. Waveband switching is by means

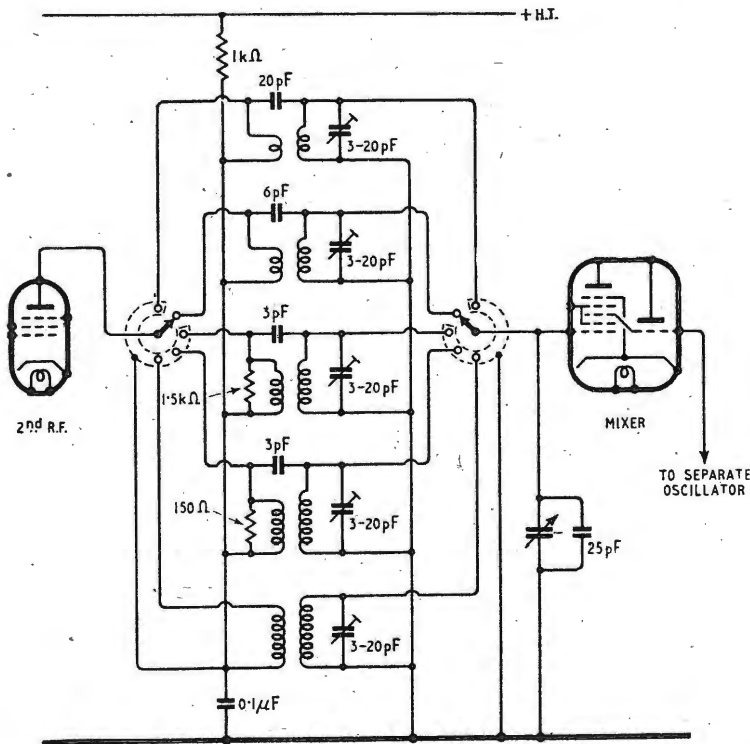

Fig. 1. Typical of the r.f. stages in the Model 680 this interstage coupling is between the second r.f. and mixer valves.

Eddystone Model 680—

of ganged wafer switches and the general arrangement of the circuit is shown in Fig. 1, which depicts the inter-stage coupling between the second r.f. stage and the mixer. It is typical of the other r.f. couplings.

A triode-hexode is shown in the mixer position but a separate oscillator valve is actually employed, only the hexode part giving service as the mixer. Its triode section is ignored although the triode grid pin is utilized for oscillator injection. The idle

is the crystal filter, this being the usual form of bridge-connected circuit with the crystal balancing, or, as it is sometimes called, the phasing capacitor, controllable from the front panel. It can thus be used to give high attenuation of an interfering carrier on either side of the desired signal and this is the so-called "single-signal" technique which will be familiar to users of communications sets.

Included in the circuit of Fig. 2 is the first i.f. valve and the signal strength (or "S") meter and its controlling diode. The

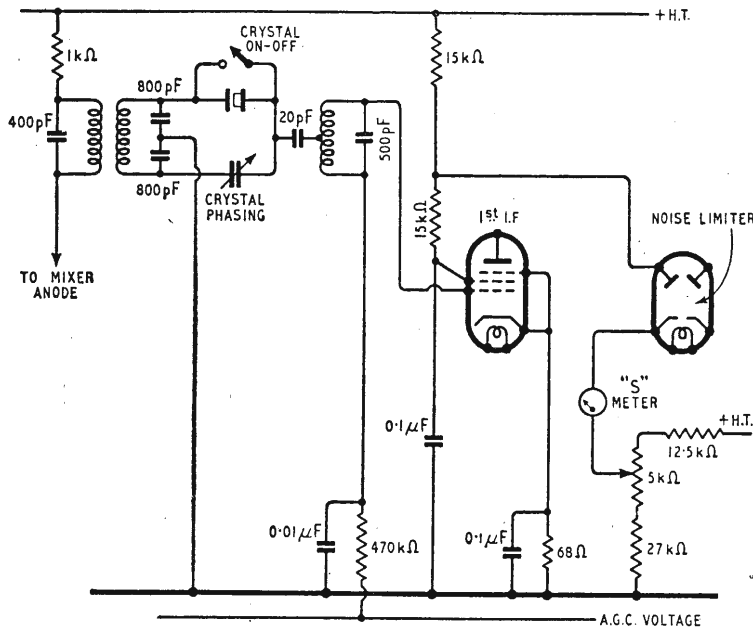

Fig. 2. The crystal filter is included in the first i.f. coupling following the mixer valve. Shown also is the diode and source of voltage controlling the "S" meter.

anode is joined to the cathode. As an alternative to the X81 or 7S7, which are the triode-hexodes favoured, an ordinary hexode mixer, such as the 6BE6 may be used in some receivers. The particular model reviewed here had the X81.

The separate oscillator valve is an 8D3 pentode but triode-connected in an orthodox form of the familiar back-coupled oscillator using shunt-fed anode coils. Fixed tracking capacitors are used on all five ranges and circuit trimming is taken care of by adjustable dust cores and small ceramic pre-set capacitors.

Immediately following the mixer, and as shown in Fig. 2,

meter is actuated by the change in G_2 current under the influence of a.g.c. but responds to the voltage drop in this electrode's series feed resistors. It does not, however, function when receiving c.w. or m.c.w. with the a.g.c. switch in the "off" position.

In order to derive the full benefit from a crystal filter, the filter must be supported by a chain of really good tuned circuits. In the Model 680 all the i.f. transformers, like the signal circuits, have dust cores and the grids of the valves are tapped down the secondary windings in order to relieve the circuits of undue damping. Circuits of quite high "Q" are thus obtained.

The i.f. amplifier has seven tuned circuits in all, three being in the crystal filter, and they are tuned to approximately 450 kc/s by fixed capacitors of 400pF, the final tuning to this frequency being effected by the adjustable dust cores.

Two stages of amplification are employed using 6BA6 valves, which are the latest button base r.f. pentodes with B7G bases. Both are included in the a.g.c. system, which, with the two r.f. valves, makes four controlled stages in all. Exceptionally good control of the audio output is thus obtained; the a.g.c. characteristic shows that for a change in the input signal of about 100 db the audio output does not vary more than 9 db. Considerable delay is allowed before a.g.c. becomes operative and this amounts to about -13 volts. It is derived from the bias resistor of the output stage and is achieved by joining the cathode of the a.g.c. diode to the cathode of the output valves. This diode is the companion to the detector, which of course operates without a delay voltage, and the two form one of the 6AL5 valves used in the receiver.

The detector circuit is more or less orthodox except that the diode load consists of four resistors joined to a switch which is linked with the bandwidth control. By taking the a.f. output from an appropriate tapping on the diode load for each position of the selectivity switch, some compensation is made for variations in the i.f. gain that inevitably accompany changes in bandwidth, no matter what system is employed.

Further compensation for variation in i.f. gain with change in bandwidth is also provided and this takes the form of adjusting the stage gain of the second i.f. valve. It is effected by switching in different bias resistors, the switch being part of the bandwidth control.

Following the detector is a series-connected noise limiter, the diode being the companion to the one controlling the "S" meter. These two form the other 6AL5 valve in the set. Details of the detector circuit, and of the noise limiter, which incidentally can be switched in or out as

required, are included in Fig. 3.

From the noise limiter the audio output passes to a volume control, then to a 6AU6 voltage amplifier and from there, through a phase reversing stage, (another 6AU6) to a pair of 7D9 output valves operated in push-pull. Some negative feedback is applied from the anodes of the two output valves to the anodes of the two penultimate valves. The output transformer has a ratio to suit a loudspeaker of between 2 and 3 ohms impedance.

Provision is made for reception with high-resistance headphones, a jack being included in the anode circuit of the first 6AU6 valve and connected so that when the 'phones are plugged in the output and phase reversing stages are isolated.

The b.f.o. valve is a 6BA6 connected as a triode and the circuit is the well-known electron coupled arrangement. This is a particularly stable form of oscillator and so is well suited to a set of this type, which needs a very stable oscillator for heterodyning the signal when the crystal filter is in circuit. Stability is

As the stability of the frequency changer oscillator is every bit as important as that of the b.f.o., the stabilized h.t. is fed also to this valve and to the screen grid of the mixer, but not to its anode

(b) With the lid raised all valves are accessible, so also is the mains transformer for voltage adjustment. To trim the circuits, it is necessary to withdraw the chassis from the cabinet.

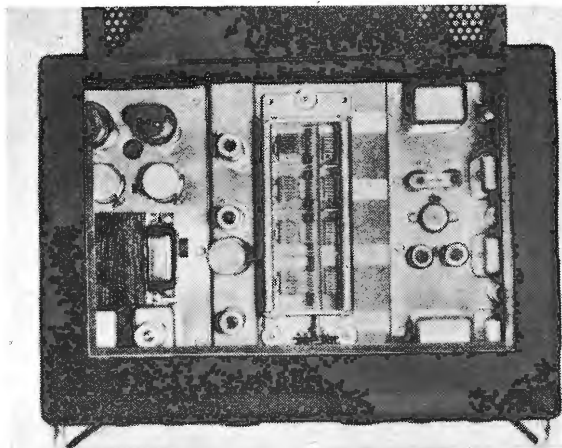

Tappings on the mains transformer provide for operation on 110 and 200 to 240 volts a.c. at normal supply frequencies.

which joins to the common h.t. line.

The receiver is self-contained, so far as the provision of all operating voltages is concerned, and it includes a mains transformer, a 5Z4G rectifier, stabilizer, as already mentioned, and adequate smoothing circuits. The

Although the receiver is not in the most expensive class (the price in the United Kingdom is £85) it is none the less a delightful set to handle. The 140 to 1 reduction in the tuning mechanism provides a precision of control that is most essential on the higher frequencies, yet it is not a tedious control to operate as it embodies a heavy fly-wheel which serves to carry the pointer from one end of a range to the other with but three spins of the tuning knob.

Despite the low gearing, no trace of backlash could be detected, although quite a long chain of gears are used. These are all spring-loaded and of the split-wheel type. Similar gears drive a small subsidiary dial

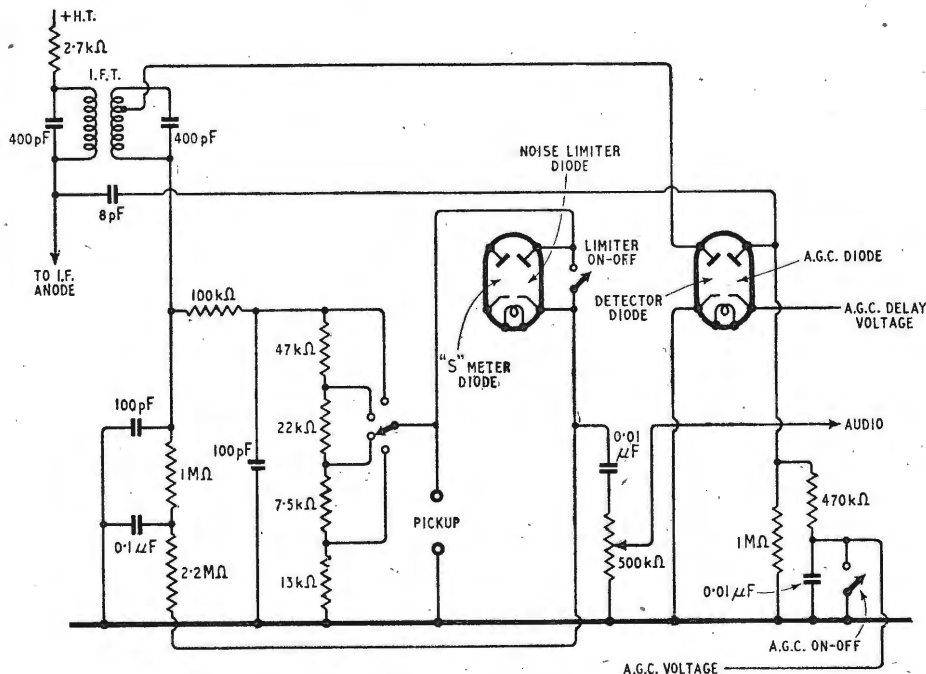

Fig. 3. Detector and noise limiter circuits of the Model 680. Included is the switching of the detector diode load and also the a.g.c. system.

further ensured by stabilizing its anode voltage, the stabilizing medium being a VR150/30 neon tube.

smoothing choke is of generous size and the two associated capacitors are 16 and 40μF respectively, the 16-μF being the reservoir.

which serves the equivalent of band-spreading, at least so far as logging stations is concerned. It is geared eighteen times faster

Eddystone Model 680—

than the main pointer and has ten inclined scales, each 1 in long, with a total marking of 100 divisions.

On the highest range, which is the longest or outer scale on the main dial, a scale length of 10 in is available and, with the subsidiary dial 20 in total. But as the subsidiary dial makes nine complete revolutions for the pointer's coverage of the main scale, it provides the equivalent of 90 in. of scale on this range. On the lowest frequency range, which is the inner calibrated scale, the effective length becomes 43 ins. In addition to the frequency calibrated scales there is a small logging scale on the main dial engraved 0-9. Thus to log a station it merely suffices to record the range (e.g., 1-5) the area on the 0-9 scale and the setting on the 0-100 bandspread dial. For example, a station on 9 Mc/s can be recorded as R2397½ as it is in range 2, comes in division 3 on the 0-9 scale and tunes in at 97½ on the bandspread dial.

So many receivers have smallish tuning knobs that it is a welcome change to handle a set with one of generous size. The two principal controls on this set—the tuning and the wavechange switch—are 2 in in diameter and have fluted edges into which the fingers sink comfortably.

Subsidiary Controls

Grouped on either side of the large knobs, and in two rows, are the subsidiary controls. On the left the upper pair of small knobs are for r.f. gain and b.f.o. pitch control, while below, are three toggle switches which, reading from left to right, serve the functions of power on-off, send or receive and b.f.o. on or off.

For reception the send-receive switch has to be in the down position and h.t. is then supplied to the valves. In the up, or off, position the h.t. supply is interrupted, but the heater supply to the valves is maintained. In addition, a second pair of contacts on the switch close and they can be used to operate a starting relay in a transmitter, either locally or at a distance. A pair of terminals at the back of the set join to these contacts.

The right-hand group comprise the crystal phasing capacitor and a.f. gain controls in the top row, and below, three switches for (from left to right) noise limiter on-off, a.g.c. on-off and bandwidth selection. Immediately above the crystal phasing capacitor is a flush-type thumb-operated switch for bringing the crystal into use when required.

This disposes of all the controls on the front panel, but there are two more located at the rear of the set. One, which is adjacent to the mains input socket, is an unusual fitting, as it is a small rheostat for adjusting the brightness of the dial light. At the opposite end of the set, and close to the loudspeaker connections, is a screwdriver slotted spindle for "zeroing" the "S" meter. This spindle is normally covered by a screw-on cap. The telephone jack is not very obvious as it is located on the left edge of the front panel, which, in this set, is slightly

dished with short, straight sides which rabbit into the main body of the metal cabinet.

The performance of the set on all wavebands should satisfy the most fastidious, and whether one is searching for a particular station, be it for traffic purposes, for a broadcast programme, or may be for an elusive and rare amateur DX station, the "680" has an uncanny knack of pulling the wanted signal out of the jumble that exists on most well-used bands.

When using the b.f.o. for c.w. reception it is necessary to have the a.f. volume control well advanced and regulate the output by the r.f. gain control. If the a.f. gain is turned too low the heterodyne beat appears to be very weak.

It has previously been mentioned that the output stage is push-pull, but this does not mean that a great deal of audio power is available. The pair of 7D9 miniature pentodes take about 16 mA each only, and for traffic handling, where a little distortion is of no consequence, an audio output of 5 to 6 watts is available. For high-quality broadcast reception this should be reduced to about 2 watts for distortionless reproduction over the widest possible range of audio frequencies.

A few words regarding the cabinet may not be out of place here. As befits a professional type of receiver, it is functional rather than ornamental, although this does not mean it is unpleasing in appearance. The rounded edges of the front and back actually tend to make the set look somewhat smaller than it actually is. The controls are conveniently placed, the dial is large but not overpowering and the louvred front and sides give adequate ventilation for all purposes.

The cabinet and front panel are finished in black crackle enamel with chromium plated carrying handles. All knobs are black. Overall dimensions of the set are: 16½ in wide, 13¾ in deep and 8¾ in high. The weight is 41 lbs. Access to the inside of the set is given by a flush-fitting hinged lid in the top of the cabinet.

The makers are Stratton and Company, Eddystone Works, Alvechurch Road, West Heath, Birmingham, 31.

NEW RADIOGRAMPHONE

Formerly made only for export, the H.M.V. Model 5302 with bandspread tuning on short waves and automatic record changer is now available in the home market, the price being £72 4s. 10d. (including tax).

NORTH AMERICAN BROADCASTING

ALTHOUGH the basic differences between the methods of broadcasting in Britain and North America are well known, the more detailed implications of these differences lead to results which are so strange to the British way of thinking that some description of them may be of interest. Fundamentally, all medium-wave stations in the United States are privately owned, either individually or in networks, while in Canada the situation is a combination of the American and British systems, since the private stations and those of the Canadian Broadcasting Corporation work side by side. This arrangement is further complicated in Canada by the fact that the C.B.C. in co-operation with the Department of Transport also grants the licences to broadcasting stations, which in the U.K. is, of course, a function of the G.P.O. In the U.S. the licensing body is the Federal Communications Commission.

Channel Sharing

The first fact that strikes a newcomer to the North American Continent is the really enormous number of stations which exists. The latest figures give more than 2,000 for the U.S. and 120 for Canada, as compared with the 320 listed for the whole of Europe under the Copenhagen Plan (*Wireless World*, Nov. 1948). With the 10 kc/s channel spacing employed in N. America there are only 107 different channels in the medium-wave band (540-1600 kc/s) so that a great amount of channel sharing is necessary. The situation is only prevented from becoming chaotic by an interesting licensing technique which acts on a "first come, first served" principle. This may best be explained by outlining the procedure which is adopted for putting a new station on the air.

Let us assume that some town has reached such a size that an enterprising business man (probably having no connections with either the entertainment or engineering worlds) decides that it can

Comparing Britain with Canada and the United States

By

ROBERT H. TANNER

(Northern Electric Co. Ltd., Canada, formerly in B.B.C. Research Dept.)

support a radio station, or another station if it has any already. This means, in simple terms, that there are enough advertisers lacking other radio outlets to make the operation of an additional commercial radio station economically feasible. The question as to whether or not listeners in the neighbourhood *want* another station does not arise. The promoter of the station will proceed with the preparation of a "brief" for submission to the licensing authority, part of which will deal with the purely commercial aspects of the matter—showing that the district can support a radio station—while the rest, prepared by a consulting engineer, will be technical.

This technical brief sets out among other things, the proposed frequency on which the station shall work together with the desired power, and the means by which all existing stations on this and adjacent channels can be "protected" from interference, both by day and by night. This latter section is, of course, the crux of the whole matter. All new stations, unless of very low power, have to resort to directional arrays with a multiplicity of towers in order to produce the complicated polar diagrams required to give reduced field strengths in the directions of the stations occupying the same or adjacent channels.

The complete brief is submitted and the decision is finally made as to whether the establishment of the new station can be justified on both commercial and technical grounds. If an affirmative answer is given, the promoter is then

free to begin the construction and equipping of his premises. Before a final licence to broadcast is given, however, he must furnish the authorities with a "proof of performance"; that is, sufficient evidence in the form of field-strength measurements, etc., to prove that the night radiation pattern is, within limits, the predicted polar diagram given in the brief. Even then, he is not entirely safe, as an existing station may complain that his signal is causing interference in which case, after investigation, he may be called upon to modify the polar diagram to eliminate the cause for complaint. It should be mentioned that throughout the licensing procedure, the Canadian, American and Mexican authorities work in close collaboration.

Listener Service

But **how** does all this affect the listener? Does he get a better service as regards technical coverage, choice of programmes and actual programme material than the average British listener? These questions are, of course, almost impossible to answer, as matters of personal preference, prejudice and taste enter into them. But there are certain definite facts which may help the reader to form his own opinion. During the daytime the average British listener can pick up only two B.B.C. stations which will, however, be broadcasting the contrasting Home and Light programmes. In the evening, these will be joined by the Third programme, as well as by a large selection of Continental stations. In general, owing to the prevailing use of high-power transmitters, combined with the high density of population, there is little difference between the services afforded British listeners in the country and in the bigger towns.

In Canada and the United States the situation is very different. In the big towns, the listener will have the choice of a comparatively large number of stations, although some of these may shut down at dusk to avoid

North American Broadcasting—

causing sky-wave interference with another station on the same frequency. To give two Canadian examples; Montreal has six stations (two of which are French) while Toronto has five. On the other hand, in a small town or in the country, daytime listening may be restricted to one local station (probably 1 kW or less) together with somewhat doubtful reception of one or two high-powered stations within a radius of 100 miles or so. At night, of course, the more remote stations will be receivable, but the interference level will increase very considerably and many channels will be little more than a confused jumble. For example, while listening in Southern Ontario it is frequently noticed that a station about 120 miles away would fade out, to be replaced by one talking Spanish, presumably in Mexico.

Networks and Local Stations

On the whole, however, it would seem that the average American listener can usually pick up more stations than his British counterpart, but this does not always mean that he has a greater choice of programmes, or that if his choice is greater the quality of the material broadcast is all that might be desired. There are two main reasons for this. First, throughout both the U.S. and Canada there are extensive networks to which stations may be affiliated and whose programmes they may transmit. This means that, during the evening when the "high spots" are broadcast, almost every station is taking one of the four big network programmes, thus greatly restricting the available choice. Listeners near the U.S.-Canadian border are in a somewhat advantageous position in this respect, as they are often able to pick up programmes originating in either country.

The second factor, affecting the quality of the programmes rather than the choice available, is economic. The comparatively small local station, when it is not taking network programmes, has to fall back on local talent for live shows, or on programmes built up from "transcription

libraries." These consist of collections of 16-in recordings (33 $\frac{1}{2}$ r.p.m.), either hill and dale or lateral, which usually carry four or five selections a side, each selection lasting two or three minutes.

It must be remembered that these local stations perform a function which is the radio equivalent of a local newspaper, a service which is almost completely lacking in British radio. News of local people and events; talks by local personalities and on matters of local interest, all form an important part of the programmes of these "community" stations and serve to bring radio more intimately into touch with the personal lives of the listeners.

At the other extreme is the situation in New York, where there are about 15 medium-wave stations, to say nothing of the f.m. and television transmitters. Most of these possess very excellent and adequate studio facilities and together they provide a very complete and varied fare. One particular station, owned by the *New York Times*, broadcasts practically nothing but classical music (mainly from gramophone records) together with short news summaries every hour.

A summary of this sort would not be complete without a few words about television. The number of American stations is, of course, startling by British

standards. The most recent figure is 45, with 77 under construction, while an F.C.C. official has forecast a total of 1,000 within the next seven or eight years. Many of the stations in action try to put out continuous programmes from morning to night and although the average quality of programme material is said to be vastly better than it was a year ago, it is thought by competent observers to be still behind the standards which the B.B.C. has set. All the programmes are sponsored and a great deal of thought is being put into the business of making the visual advertising items as attractive as possible, lest it fall into the disrepute of the sound "commercial."

Just at the moment, the F.C.C. is having second thoughts about the distance which must be allowed between television stations operating in the same channel and all new building has been suspended. On the other hand, the Canadian authorities, after an interval of waiting to see how things were going south of the border, have just decided to take the plunge, and construct television stations in Montreal and Toronto. In addition there are plenty of private concerns, some with British backing, most anxious to make a start on what, in Canada at least, is still a new and virgin field.

AMERICAN RADIO

F.C.C. Annual Report

THE fourteenth annual report of the American Federal Communications Commission reveals that the number of a.m., f.m. and television broadcasting stations in the United States has more than trebled in the past three years. At the end of last October, the closing date of the report, licences had been issued for 2,103 a.m. stations, 996 f.m. and 124 television transmitters.

The number of authorized broadcasting stations, including 168 experimental television transmitters, 46 non-commercial educational stations, 37 international broadcasting stations and 578 radio-link transmitters, totalled 4,091, an increase of some 500 during the year. It should be pointed out that these figures cover the number of stations authorized to operate; in actual

fact, so far as television is concerned, the latest figure given by the chairman of the F.C.C. is 60 stations, which, operating in 30 cities, are said to cover areas containing 40% of the country's population.

The number of non-broadcasting stations is given in the report as nearly 55,000, in addition to which there were in October 81,170 amateur stations and over 1,000 telegraph and telephone stations. Aeronautical services head the non-broadcasting list with nearly 25,000 stations, whilst marine services come next with 17,000. Taxicabs hold licences for 3,188 transmitters, whilst railway radio, which was introduced in 1945, now employs 235 transmitters—nearly double the previous year's figure—on 40 different railways.

THE "BELLING-LEE" PAGE

Providing technical information, service and advice in relation to our products and the suppression of electrical interference

"BELLING-LEE" TELEVISION AERIALS to suit every pocket and every location

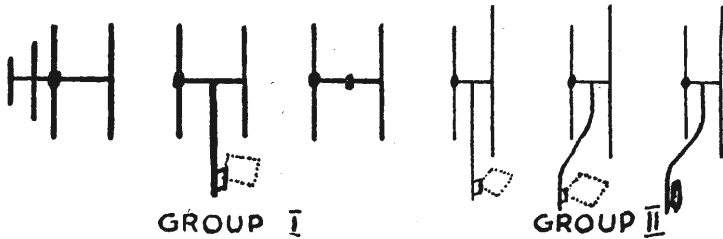

The new season's range of "Belling-Lee" television aerials comprises sixteen types for both the London and the Midland frequencies.

They may be divided into four groups: (1) aerials for "fringe" areas, including a new beam; (2) a new range of lightweight aerials with 0.15λ spacing; (3) dipoles including the "Veerod," and a new outdoor "Twinrod" and (4) indoor aerials including the "Doxrod" and the new "Viewflex."

Group (1) will be represented by the present robust "H" type, and a new beam which can be seen at Radiolympia.

Group (2). Up to date, all "Belling-Lee" television aerials have been designed to withstand repeated wind gusts of 100 miles per hour: because of this we rarely, if ever, see a "Belling-Lee" aerial distorted. Now that the prices of television receivers are falling so rapidly, the prices of these exceptionally robust aerials are out of all proportion, and every device has had to be examined whereby a considerable economy could be effected.

It is obvious that locations where 100 m.p.h. gusts occur are limited to certain coastal areas, or exceptionally high and exposed inland sites, and representing a very small proportion of the total number of aerials sold. It is, therefore, not unreasonable to ask why the many should pay for the few.

An obvious reduction in price can be achieved by saving material on certain types of aerials, but we must continue to manufacture a smaller quantity of the truly robust types which have made our name, and which will still be required for exposed areas.

The elements of the new types

will be reduced from $\frac{1}{2}$ in to $\frac{3}{8}$ in. diameter, and the distance between dipole and reflector will be reduced. This raises the old controversy of picture flutter in wind $\frac{1}{4}\lambda$ v $\frac{3}{8}\lambda$ spacing, etc. Picture flutter is bound up with the rate of change of gain with separation of dipole and reflector. From zero spacing to $\frac{1}{4}\lambda$ the gain rises rapidly, and thereafter falls very slowly to about 1 db at $\frac{1}{2}\lambda$.

The effect of flutter may be demonstrated by anybody with the aid of a string on the tips of the elements, by which they are pulled while the picture is being watched. There are two schools of thought, and we are ready to admit that we may have overrated the appreciative faculties of the public who are obviously prepared to tolerate a somewhat inferior picture in certain bad weather conditions. We are, however, not going to reduce the spacing of our new aerials to $\frac{1}{4}\lambda$ but 0.15λ , i.e., approximately $\frac{1}{7}\lambda$; at this distance picture flutter is not likely to be troublesome as the curve depicting it is fairly flat between $\frac{1}{4}\lambda$ and $\frac{1}{2}\lambda$. This allows us to reduce pole diameters from 2 in. to $1\frac{1}{2}$ in. and to supply lashings and cross-arms of lighter materials.

Group (3) requires little explanation except that the new "Twinrod" which might be described as the marriage of the "Doxrod" and "Winrod" for window sill mounting, and may be used either for broadcast or television reception.

Group (4) includes the new "Viewflex" which is the natural development of the "Doxrod" as an all flexible dipole.

"Wires that carry and re-radiate interference"

We have got ourselves into trouble over this heading and we agree that it is ambiguous.

We certainly never intended to give the impression that relay operators fed an interfering signal on to their lines: they do not. We do say that any wire can pick up by induction, interference radiated from another nearby conductor. This in turn can be re-radiated, and is sometimes referred to as secondary interference. We know that relay authorities are most anxious to keep interference off their lines, and if they are told of any such interference will quickly take necessary steps to have it suppressed at source.

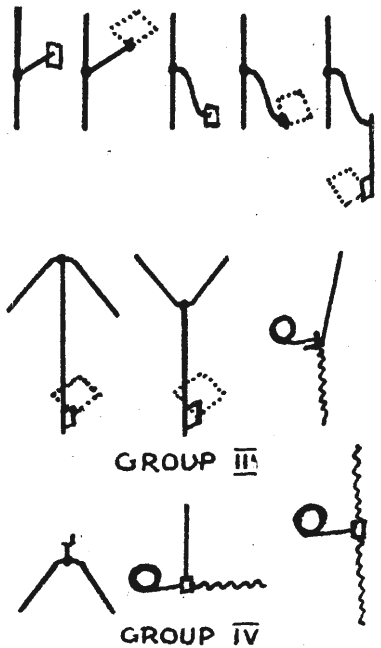

Rattle-free Car Aerial

We will shortly be releasing the new "Belling-Lee" car aerial which is absolutely rattle-free. It is stainless steel with streamlined collet grip at centre, and with streamlined insulators. This is a truly de-luxe model.



S.R.E.* for all purposes

Philips have supplied through traders and others throughout the world S.R.E. for almost every conceivable application. While specialized equipment is produced whenever necessary, a very wide range of standard apparatus units minimizes the need for this, and simplifies installation and maintenance.

As it can be shown to be much better engineering practice to use one large amplifier instead of a lot of little ones to feed one load, the standard range includes three large rack amplifiers.

Features include triode valves throughout, four push-pull stages, no electrolytics, and three separate anode supplies.

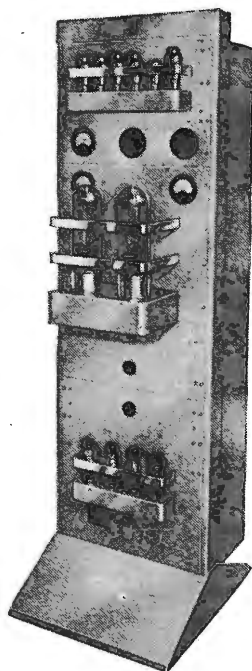

* What expression should be used to refer generally to amplifiers, and related apparatus? "Public Address?" This hardly applies to gear that may well be used in private for purposes other than addressing. "Sound Equipment?" This can also mean tomtoms, or brewery apparatus in sound condition! We have adopted the Navy's term "S.R.E." or "Sound Reproducing Equipment", as in our submission there is no other so accurate or so generally applicable.

- 250 wattList Price £255
- 500 "List Price £325
- 1,000 "List Price £425

S.R.E. available through the trade on hire purchase or rental terms.



PHILIPS ELECTRICAL LIMITED

Amplifier Dept., Century House, Shaftesbury Avenue, London, W.C.2. (A48r)

TRANSFORMER SPECIALISATION



We specialise in satisfying the requirements of Industrial, National and Medical Research Establishments. Many of your needs may be met from the Standard range of "Somerford" Transformers and Chokes which are available by return. In addition to these we have our extensive range of special duty types and we shall always be happy to advise on the most suitable component to meet any specific requirement. Drawings of the various mechanical constructions available may be had upon request and specialised windings are carried out by our own skilled technicians.

The photograph shows six of the series

- 1 Hengist 2 Twynham 3 Avon 4 Burley
- 5 Somerford 6 Hermetically Sealed E.H.T.

GARDNERS RADIO LTD

SOMERFORD CHRISTCHURCH NANTWICH

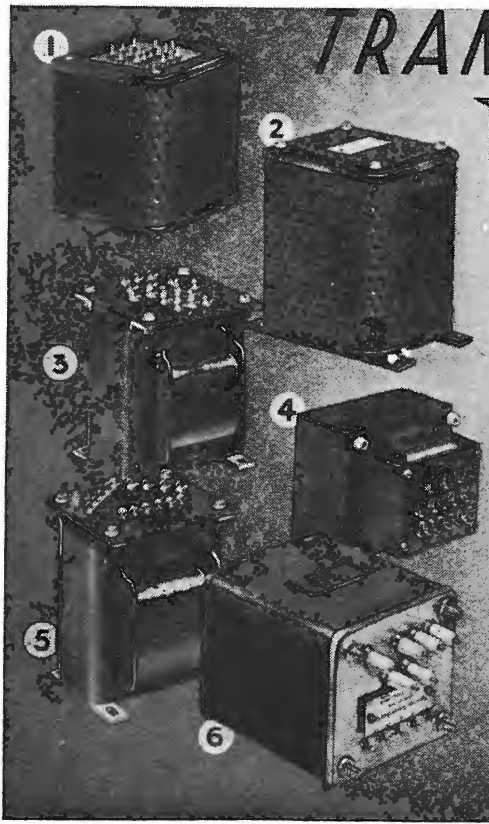

WORLD OF WIRELESS

Cost of Suppression ♦ Television Progress ♦ Standard Audio Frequencies ♦ R.A.F. Distress Calls

W.T. Act

THE Wireless Telegraphy Act, 1949, has now been placed on the Statute Book, it having received the Royal Assent at the end of the last Parliamentary session.

Very few amendments have been introduced since the second reading of the Bill. The House of Lords amendment that a person should not be liable to spend more than 2s in suppressing each piece of domestic electrical apparatus used by him, was rejected. The reasons given by the House of Commons were that it was considered to be wrong that a person should be allowed to interfere with the amenities of his neighbours "merely because the cost of abating the interference would exceed an arbitrarily fixed amount," and that if this were permitted "the voluntary collaboration on which the Government must . . . rely for the control of interference would be undermined."

American Television

FOR some months past, there has been a standstill in the United States so far as the erection of new television stations is concerned. During this time the Federal Communications Commission has been considering what steps should be taken to ensure the healthy development of television to provide a national service.

The Commission has now issued a comprehensive plan providing for some 2,245 stations in 1,400 districts having a total population of over 69,000,000. In addition to the use of the 12 existing channels in the 54- to 216-Mc/s band which, according to the plan, provides for 543 stations, it also proposes the use of forty-two 6-Mc/s channels above 470 Mc/s. The maximum power of stations in the existing channels is to be raised from 50 to 100kW, while stations in the new band may use 200kW.

The distance separating stations using the same channels in the lower band has been increased from 150 to 220 miles and users of adjacent channels from 75 to 110 miles. In the higher band the separations are slightly less. No provision for protection against occasional long-distance propagation is made in the plan, as it could be accomplished "only by severely limiting the number of stations" in each channel.

T H A M E S RADAR. — A reproduction of the P.P.I. display on a Marconi "Radiolocator", the scanner of which was installed on the roof of the I.E.E., Victoria Embankment. The annotation is self explanatory.

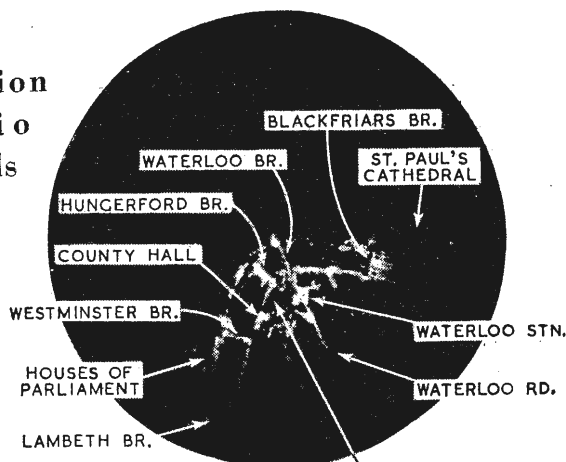

CLEARED SITE FOR 1951 EXHIBITION

Provision is made in the list of channel allocations for as many as seven stations to a city such as Chicago. The plan also takes into account the proximity of Canada, Mexico and Cuba to the U.S. borders and lists frequencies for use in those countries. The F.C.C. suggests that the four Governments enter into formal agreements on television frequency allocations as soon as possible.

According to the list published by our Washington contemporary, *Broadcasting*, some districts will have stations in both the lower and higher bands.

Anglo-French Television Agreement

WHAT may prove to be a step towards the establishment of a standard for European television has been taken by France. Following a recent meeting of the C.C.I.R. (International Radio Consultative Committee) in Zurich, it was announced that the French Government had agreed to change its present Eiffel Tower 455-line transmissions to 405 lines, the British standard. It is understood from a French correspondent that the change will be made in October. It will be recalled that when the decision was made at the end of last year to introduce 819-line transmissions, it was stated that the medium-definition transmitter serving the Paris area would continue operating until January, 1958. The new 819-line station in the Eiffel Tower, operating on 213.25 Mc/s started experimental transmissions in April.

Radiolympia

IN preparation for the 16th National Radio Exhibition which opens at Olympia on September 28th, the Radio Industry Coun-

cil, who is organizing the show, has issued a booklet entitled "British Radio for the World" for overseas distribution. Articles on various aspects of the industry are included. Among the contributors are Sir Edward Appleton and Dr. R. L. Smith-Rose.

The exhibition will be open daily, except Sunday, from 11 a.m. to 10 p.m. until October 8th. Admission will be 2s 6d.

In the next issue of *Wireless World* we plan to include a guide to the exhibition.

B.B.C. Tuning Notes

HAVING received inquiries from readers regarding the accuracy of the frequency of the B.B.C. tuning notes—or line-up tones as they are called—we have secured the following details from the B.B.C. Engineering Division.

The frequency radiated immediately before the opening of the evening's Third Programme is 440c/s and that preceding the day's Home Service and Light Programme is 1,000c/s. The frequencies are normally maintained to an accuracy of ± 1 part in 10^6 . It is pointed out that frequencies different from these are sometimes used for test purposes outside normal broadcasting hours.

Distress Calls

SINCE the recent broadcast by the B.B.C. of an appeal for news of calls from a missing R.A.F. aircraft, amateurs have asked for details of the frequencies on which these calls would be radiated.

The R.A.F. has therefore issued the following information. An R.A.F. aircraft should send out an emergency call on the wavelength of the station with which it is working. It then has the choice of making a general S.O.S. call using

World of Wireless—

any one of the following frequencies:—

(a) 6,500 kc/s by day (0600 to 1900 G.M.T.), or 3805 kc/s by night;

(b) 370 kc/s used for long-range D.F.;

(c) 116.1 Mc/s used for R.T.; or

(d) 500 kc/s, the international S.O.S. frequency.

When an aircraft crew has taken to the dinghy they will use the automatic S.O.S. transmitter which operates on 500 kc/s.

It is pointed out that between 15 and 18 minutes past each hour and between 45 and 48 minutes past each hour, by international agreement, a radio silence is observed on the international S.O.S. frequency for listening-out purposes.

Marine Radio Gear

A SERIES of revised specifications for marine radio equipment is being prepared by the G.P.O. after consultation with the Ministry of Transport, the shipping companies and radio manufacturers. This has been necessitated by the increasing congestion of the frequency spectrum, changes in technique and the requirements of the Atlantic City Radio Regulations and the International Convention for the Safety of Life at Sea.

The latest specification gives minimum requirements for radio-telephone equipment. It is issued purely for the guidance of manufacturers in order that they may, where necessary, modify the design of their equipment to comply with these requirements, which will eventually become operative.

The booklet containing these specifications is entitled "Radio for Merchant Ships—Performance Specifications for Compulsorily and Vol-

untarily Fitted Radiotelephone Equipments." It is obtainable from H.M.S.O., price 6d.

Sound Reproduction Equipment

A COMMITTEE has been set up by the British Radio Equipment Manufacturers' Association to deal with questions relating to the design, manufacture and distribution of sound reproduction equipment which is defined as "an electrically operated amplifier, to the input of which is attached a source, e.g., microphone, gramophone or radio, the output being fed into a loudspeaker or a series of loudspeakers." (Component parts of such apparatus are not included.)

The use of the term "public address equipment" is deprecated by the committee, which proposes the adoption of the term "sound reproduction equipment." The scope of this committee, on which is represented twelve manufacturers, is defined as covering equipment for sound amplifying and broadcasting systems, manufacturing and technical aspects of relay equipment and sound reproduction by means of tape recorders.

OBITUARY

J. H. Runbaken, the founder and managing director of Runbaken Electrical Products, of Manchester, died on July 18th.

PERSONALITIES

Sir Robert Watson-Watt has been nominated vice-president of the American Institute of Radio Engineers for 1950.

Air Comdre. R. L. Phillips, C.B.E., who has been appointed Director of Radio at the Air Ministry, was, until recently, Senior Air Staff Officer at No. 90 (Signals) Group and was formerly Chief Signals Officer at Fighter Command H.Q.

H. C. Baker, of Bush Radio, has been appointed B.R.E.M.A. representative on the R.I.C. exhibition organizing committee in place of H. J. Dyer who was, until recently, with Philips.

E. R. Barnett has been appointed by E. K. Cole to advise Ekco dealers in the Midlands television area on receiver sales and service. He will operate from the Ekco service depot at 11, Brook Street, Birmingham, 3.

Derrick Beecham, who resigned from Furzehill Laboratories last year and has been acting as an independent sales consultant, has been appointed managing director of Bowdler, Godfrey and Co., exporters and importers.

S. Erickson, who has been chief design and development engineer to Vidor, Ltd., since early 1948, has resigned to take up a Government research appointment.

C. R. Nortcliffe, export manager of Philco (Overseas), Ltd., has been appointed by the Philco Corp. of Philadelphia as its sales manager for Europe and North Africa.

J. W. Ridgeway, a director of Ediswan's and manager of their radio division, has been elected chairman of the British Radio Valve Manufacturers' Association for the current year. The new vice-chairman is **G. A. Marriott**, of the G.E.C. valve department.

G. S. Taylor, who, prior to the war, was sales and advertising manager of the Whiteley Electrical Radio Co., has rejoined the company as a divisional sales manager. He will operate from the company's London office, 109, Kingsway, London, W.C.2. (Tel.: Holborn 3074.)

IN BRIEF

Receiving Licences.—At the end of June 11,910,850 broadcast receiving licences (including 147,900 television licences) were current in Great Britain and Northern Ireland. The increases over the May figures were "sound" 29,850, "vision" 7,050.

Amateur Exhibition.—The Radio Society of Great Britain is to hold the third annual amateur radio exhibition at the Royal Hotel, Woburn Place, London, W.C.1, from November 23rd to 26th. Admission will be by catalogue obtainable, price 1s 3d, from the R.S.G.B., New Ruskin House, Little Russell Street, London, W.C.1.

Guarantees.—It has been decided by the B.V.A. that the guarantee on valves and c.r.t.s in television sets sold for use in the Birmingham television area prior to the official opening of the station will operate from the date of the inauguration of the Midland service. In the case of combined broadcast and television receivers only the c.r.t. will be subject to this arrangement.

Northern Television.—The P.M.G. has now verified that the country's third television station will be erected at Holme Moss, Yorks. It is unlikely that the station will be in operation before the end of 1951. When publishing a map last month showing the anticipated service area of the projected station it was erroneously referred to as the *North-East* station; it should, of course, have been *North*.

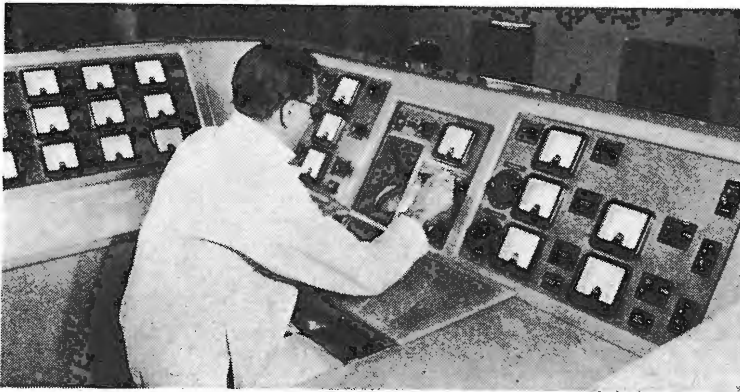

MIDLAND TELEVISION. The vision and sound control desk for the Sutton Coldfield station. The vision transmitter and this control desk are being supplied by E.M.I. and the sound transmitter by Marconi's.

Exports.—Although the value of the June exports of transmitters and radio navigational equipment increased by some £35,000 over the preceding month, the total for the first six months of the year fell by £234,000 compared with 1948. The comparative figures are: 1948, £1,667,652; 1949, £1,433,378. The increased export of domestic receivers to some of the countries in the commonwealth has been counter-balanced by the fall in exports to the "hard currency" countries. Brazil's purchases during the first six months in 1948 total £172,673 compared with £1,755 this year. The only section of the industry showing an increase during the six months under review was components. The exports rose from £1,307,025 to £1,516,270.

Electronics Symposium.—The Electronics Section of the Scientific Instrument Manufacturers' Association is to hold a series of meetings at the Examination Hall, Queen's Square, London, W.C.1, from November 2nd to 4th, at which a symposium of technical papers will be given. Details of the programme, and of the exhibition of scientific and electrical instruments which will be run in conjunction with the meetings, are obtainable from the Association, 17, Princes Gate, London, S.W.7. Admission to the meetings will be by ticket.

Evening Courses in telecommunications and radio and television servicing are included in the prospectus issued by the Electrical Engineering Dept. of the Polytechnic, Regent Street, London, W.1. The telecommunications courses are approved for the award of the "Ordinary" and "Higher" National Certificates granted by the I.E.E. in conjunction with the Ministry of Education, and are also recognized by the City and Guilds as preparing for their examinations. The courses on servicing prepare for the Radio Servicing Certificate awarded jointly by the City and Guilds and the Radio Trades Examination Board. Students for the session commencing on September 26th must enrol on September 21st or 22nd between 6 and 8 p.m. The prospectus is obtainable from H. W. Date, Head of the Department.

Room Acoustics.—A course of six lectures on "Modern Principles of Room Acoustics" is to be delivered by Prof. R. H. Bolt, director of the Acoustics Laboratory, Massachusetts Institute of Technology, under the auspices of the Acoustics Group of the Physical Society. They will be given in the lecture theatre of the Royal Institution, Albemarle Street, London, W.1, at 5.0 on Sept. 29th and 30th and on Oct. 3rd, 4th, 5th and 7th. A registration fee of 10s 6d will be charged for the course. Particulars are obtainable from I. Lowther Gardens, London, S.W.7.

Television Instruction.—Two television training centres, one in Birmingham and the other in Leicester, have been set up by the G.E.C. Five-day courses, including lectures on the fundamentals of television and practical work on the installation of receivers and the location of faults, are provided for approved dealers. Particulars are obtainable from Magnet House, Kingsway, London, W.C.2.

The courses organized by the Radio Gramophone Development Co. have been suspended until September. Applications to attend the courses, which are limited to R.G.D. dealers, should be addressed to Bridgnorth, Salop. Antiference, Ltd., have provided lectures on television aerials in some of the centres to be served by the Midland station. Particulars of future lectures and tickets of admission are obtainable from 67, Bryanston Street, London, W.1.

Ferry Radar.—Although shore-based Cossor radar equipment has been used

London Traffic Control.—Pye two-way mobile radio-telephone equipment has been installed in seven of the breakdown lorries and some of the inspectors' cars operated by the London Transport Executive to facilitate the control of traffic in the Metropolitan area. To give complete coverage of the area, four automatic receiving stations are being erected to the north, south, east and west of London, and both these and the main roof-watt headquarters' transmitter will be connected by land line to the Signal Engineer's Report Centre.



IN COMMEMORATION of the recent meeting of the C.C.I.T. (International Telegraph Consultative Committee) in Paris, the French postal authorities have issued a series of five postage stamps. Three of them, reproduced here, portray radio personalities—Emile Baudot, inventor of the ~~press~~ system of telegraphy; General Ferrié and André Ampère (with F. Arago).

for the control of the Wallasey ferry service across the Mersey for nearly two years, it was not until the end of July that the permanent installation was officially brought into service. The new Cossor equipment incorporates a 15-inch P.P.I. During ten days' foggy weather last November, 845 crossings out of a scheduled 861 were undertaken. The ferries carry some 55,000 passengers a day.

Technical Courses.—Particulars of both full-time and evening courses on various radio subjects organized by education authorities in Southampton, Walsall and Brentford have been sent to us. The day courses at University College, Southampton, include radar maintenance, radio engineering and radio operating. Part-time day and evening courses in telecommunication engineering and television and radio servicing are also provided. Particulars are available from the Department of Electronics, Telecommunications and Radio Engineering, University College, Southampton. A course covering the Radio Amateur's Examination is to commence at the Walsall Technical College, Bradford Place, Walsall, Staffs, in September. A similar course is being provided by the Brentford Evening Institute, Boston Manor Road, Brentford, Middlesex. It begins on September 21st, the fee being 7s 6d.

Delegates to the recent International Esperanto Congress in London were given the opportunity of seeing British television when the honorary president was interviewed in the B.B.C. programme "Picture Page." Six receivers were installed by the Gramophone Co.

Cable & Wireless.—In the annual report of Cable & Wireless for 1948, which has been issued as a Government White Paper, it is recorded that eleven new overseas radio-telegraphy circuits were opened—four replacing services lost during the war. The addition of seventeen radio-telephone circuits is also recorded. Four of these were in the West Indies and bring the total in that area to thirty-three. Six new radio-phototelegraphy services were introduced, five of them from London. On the research side it is recorded that work has been successfully carried out at the company's transmitting stations at Ongar and Dorchester to find a means of universal commutation between transmitters and aerials by which any transmitter can be used with any aerial.

Price Control.—Broadcast and television receivers, radio-gramophones, components and accessories were among the products recently freed from price control by the Government.

I.E.E. Radio Section Premiums for papers read or accepted for publication during the 1948-49 session have been awarded to the following authors:—G. Millington (Duddell Premium); Dr. G. F. Gainsborough (Ambrose Fleming Premium); and Extra Premiums to H. de B. Knight, Dr. W. A. Wooster, Dr. Nora Wooster, J. L. Rycroft, L. A. Thomas, Dr. D. G. Tucker, Dr. B. G. Pressey, Dr. H. G. Hopkins, F. Horner, C. F. Floyd, R. L. Corke, C. F. Booth, J. P. Johns, H. T. Mitchell, T. Kilvington, and F. E. Williams.

B.S.R.A.—The opening meeting of the British Sound Recording Associa-

World of Wireless—

tion will be held at the Royal Society of Arts on September 22nd at 7.0, when W. S. Barrell (E.M.I.), who is again president, will deliver his presidential address. In addition to the re-election of M. J. L. Pulling (B.B.C.) as vice-president, B. C. Sewell, Director of Sound at the Gainsborough Studios, and C. E. Watts, director of M.S.S. Recording, have been elected vice-presidents.

Brit. I.R.E.—It has been decided to postpone until 1951 the next international convention, which was to have been held in 1950 to mark the silver jubilee of the British Institution of Radio Engineers, in order to coincide with the Festival of Britain.

Brit. I.R.E. Premiums have been awarded to the following authors for their papers published during 1948:—The Heinrich Hertz Premium to I. A. Harris, for "Calculation of Electrode Temperatures in the Radio Valve"; Marconi Premium to F. C. F. Phillips, for "A Direct-Reading Frequency-Measuring Set"; and the Dr. Partridge Memorial Award to G. L. Hamburger, for "An Automatic Audio-Frequency Response-Curve Tracer."

Multiple Aerial.—Individual aerials installed at various points on the cable ship, *Edward Wilshaw*, might be a source of interference with the calibration of the vessel's direction-finding apparatus and, in order to obviate this, the Marconi International Marine Communication Co. has developed an aerial splitter. By means of this, a large number of receivers can be operated from only one aerial. It has the further advantage of protecting the receivers from interference effects produced by the ship's transmitters, even when operated on closely adjacent frequencies. This apparatus is part of the comprehensive radio communication and navigation equipment installed on this latest vessel operated by Cable & Wireless.

"**Wireless World**" and associated liffe journals dealing with various aspects of marine equipment and engineering are included on stand 48 at the Engineering and Marine Exhibition which opens at Olympia on August 25th.

"**Rangitoto**," the latest and largest passenger and cargo liner of the New Zealand Shipping Company, has been equipped with radio and radar by the Marconi International Marine Communication Co.

Record Processing.—In the note on page 303 of the August issue, the price of the pamphlet issued by the Association of Professional Recording Studios was given in error as 3d; it should have been 1s 3d by post.

Multicore.—Record export sales of Multicore ersin-cored solder were recorded during the second quarter of this year. Over 1,900 miles of solder were shipped to the U.S.A., one of the forty countries to which Multicore is regularly exported.

FROM ABROAD

French Exhibitions.—The French Radio Council (Syndicat National des Industries Radioélectriques) is organizing an international exhibition of radio components, accessories and measuring

instruments which will be held at the Parc des Expositions de la Porte de Versailles, Paris, 15ème, from February 3rd to 7th next year. British manufacturers, who may take part under certain conditions, can obtain particulars from the Council at 25 Rue de la Pépinière, Paris, 8ème. The Salon International du Matériel Radio-Électrique, which was to have been held in Paris from September 26th to October 2nd this year, has been cancelled.

New Zealand.—A radio-physics research station is to be established by the New Zealand Department of Scientific and Industrial Research at Manukau, near Auckland. It will be operated by Auckland University College.

Sweden.—Three more medium-wave broadcasting transmitters have been supplied by Standard Telephones & Cables to the Swedish Broadcasting Administration. Two are already in operation—a 150-kW station at Sundsvall and a 100-kW transmitter at Hörby. The third transmitter—at Göteborg—which will have a power of 150 kW, is scheduled to be in operation next year. The audio-frequency range distortion of the transmitter is said to be less than 2 per cent up to 90 per cent modulation. The transmitter has an overall efficiency of from 41 to 43 per cent.

North American Broadcasting Conference for the allocation of frequencies to medium-wave broadcasting stations in North America will open in Montreal on September 9th.

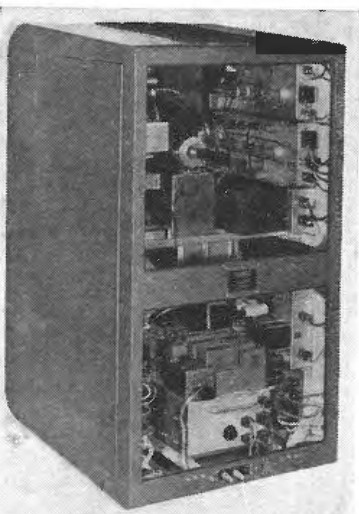

INTERIOR OF Cinema-Television monitor with 20-in cathode-ray tube operated at 13 kV; this supply is generated by an r.f. oscillator and rectifier. Designed for v.f. signals of 1-10-V amplitude from a line input, the apparatus does not include r.f. circuits. The undersides of the various chassis are accessible for maintenance by removing side panels from the cabinet.

German Amateurs.—Transmitting licences under the same conditions as those in force in the U.S. and British zones of Germany are to be issued to amateurs in the Western sectors of Berlin. Call signs will be prefixed DL7.

Mexico.—Requests for the erection of twenty-six television stations have been received by the Mexican Ministry of Communications. It is stated that licences will not be issued until the rules governing the operation of television stations have been drawn up.

Radio-minded U.S.—In a brochure issued by the American Broadcasting Company it is stated that 39,275,000 U.S. homes operate some 62,000,000 domestic receivers and over 10,000,000 car radio sets. The number of radio-equipped homes in the United States has increased by over five million in the past three years. It is forecast that next year there will be 40,250,000 radio-equipped homes, 2,750,000 of which will have television receivers.

Ecuadorian Police are seeking specifications and prices of six patrol cars equipped with radio, some of which will have to operate at altitudes up to 14,000 feet. Details of equipment should be sent by air mail to Commandant Duran, c/o The Commercial Section, H.M. Legation, Quito, Ecuador.

Chilean Agencies for domestic receivers and valves are sought by Besa y Cia Ltda, Av. B. O'Higgins 1486, Casilla 1147, Santiago, Chile.

INDUSTRIAL NEWS

E.M.I.—With a view to extending the interests of E.M.I. Research Laboratories in Australia and for the subsequent manufacture of television and electronic products in the Commonwealth, G. E. Condliffe, director of the laboratories, has gone to Australia. E.M.I. already has a factory at Homebush near Sydney and has recently acquired new premises in Sydney and Melbourne. The Australian Prime Minister recently announced that the Government had decided to install 625-line television transmitters in the six State capitals.

Change of Name.—It is proposed to change the name of the Radio and Television Trust to Cable and Electric Industries, as, since the severance of Philco from the group of companies controlled by the Trust, radio and television receivers are no longer produced by the organization. Among the companies in the group are Airmec Laboratories, British Mechanical Productions (Clix) and Hopkinson's Motors.

Ekco have opened new premises for their Scottish radio service depot at 26, India Street, Glasgow, C.2 (Tel.: Central 2012).

Industrial Sound Equipment, Ltd., have moved from 10, West Central Street, London, W.C.1, to 141, High Street, Brentford, Middlesex. The temporary telephone number is Ealing 5367.

Taylor Electrical Instruments, Ltd., announce a revision of their hire-purchase scheme permitting dealers to offer Windsor and Taylor radio test equipment for sale on hire-purchase terms.



ALTHOUGH the tube diameter in this interesting new equipment, developed by the Decca Navigator Company, is only 5 inches it is necessary to resist the temptation to describe it as a miniature radar set. True, the dimensions are less than those of any marine radar so far available, and the price (£1,500) is said to be about half that of most other equipments; but the performance complies with the Ministry of Transport's specification for marine radar, and in some respects improves upon it. The pulse length, for instance, is only 0.1 to 0.12 μ sec and the range discrimination and minimum range are of the order of 20 yds.

There are four units, as follows:—

Scanner.—Two parabolic cheese reflectors are used, one on top of the other, for transmission and reception. They are mounted immediately over the modulator unit and are driven at 20 r.p.m. by an enclosed motor. The photograph shows the scanner unit on a tubular light-alloy mast; normally a bracket is provided for attachment to any suitable part of the ship's superstructure. In addition to the transmitter, the scanner unit contains the early receiver stages.

Receiver.—This is a self-contained unit without controls and is designed for bulkhead mount-

ing. It contains the immediate and final stages of amplification, the trigger unit for the modulator, power supply for other parts of the circuit and circuits associated with the metering of overall performance. This is effected by measuring the intensity of the reflected ground ray.

The bandwidth of the receiver is 10 Mc/s at an intermediate frequency of 30 Mc/s, and the overall gain is 120 db.

Display Unit.—By retaining in this unit only those circuits connected with the working of the cathode-ray tube, the size of this unit has been reduced to the smallest possible dimensions. It has been provided with a trunion mounting so that the position of the tube is easily adjusted to the navigating officer's liking, and it can be mounted either on a bulkhead, or horizontally at the back of the chart table.

Five range scales are provided, with maxima of $\frac{1}{2}$, 1, 3, 10 and 25 miles, and there is a mechanically operated cursor for reading off bearings on the illuminated peripheral bearing scale. Ship's head is indicated by a radial trace on the screen, and electrically generated range rings can be switched on or off, the appropriate calibration being shown on the range scale indicator.

A detachable visor is provided, and, if desired, a lens giving 2:1 magnification can be fitted. The whole of the equipment is controlled from the display unit,

DECCA RADAR

Low Priced Equipment Suitable for Small Vessels

and the pre-set adjustments are normally concealed by a hinged cover. Controls always available are the range selector on the left of the tube, bearing cursor control on the right, and, at the top, toggle switches for the range rings and crystal/performance check meter.

Power Unit.—A motor generator operating from the ship's d.c. mains (110 or 220 V) forms the basis of this unit and draws about 1 kW. It is housed, together with a voltage regulation circuit, in a metal case measuring 28in \times 18 $\frac{1}{2}$ in \times 16in. The output is 1,000 c/s a.c. stabilized at 80 volts. Regulation is satisfactory for mains fluctuations between +15 and -25 per cent.

The new Decca Radar is complementary to the Decca Navigator System. The latter gives accurate fixes irrespective of land or sea marks, and the former comes into its own for collision

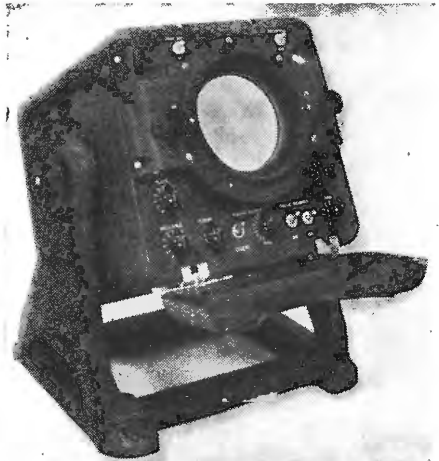

A 5-inch tube is employed in the display unit, which carries controls for the whole of the equipment.

prevention and also for pilotage.

Undoubtedly, the small size and low price of the new radar equipment should make a wide appeal to shipowners abroad as well as in this country.

ELECTRONIC CIRCUITRY

Selections from a Designer's Notebook

By J. McG. SOWERBY (Cinema Television Ltd.)

IN recent years numerous papers and articles have been published describing various types of sinusoidal oscillators whose frequency is controlled by a combination of resistance and capacitance. The avoidance of inductive components which is achieved is particularly

RC Oscillators

useful at frequencies up to 10-100 kc/s as inductances suitable for low frequencies are not easy to make, and are inconveniently large when made. In addition, a variable-frequency RC oscillator can be made to cover a wider range with a given variable component (usually a condenser) as the frequency is proportional to $1/C$ as against $1/\sqrt{C}$ in an LC oscillator.

There are a few rather important points concerning RC oscillators with which readers may not be fully conversant, and these notes are written in an attempt to clarify these points.

Any RC oscillator may be regarded as an amplifier of gain A , with an RC feedback network applied between output and input in such a way that oscillation is maintained. The RC network introduces positive feedback (and perhaps negative feedback as well) to achieve this end—as in all oscillators.

Consider first the overall gain of the arrangement of Fig. 1. If we call the overall feedback factor β in the usual way (i.e., the fraction of the output voltage fed back to the input) the net gain of the system becomes $A_0 = \frac{A}{1 - \beta A}$.

In amplifiers β is normally negative so that $(1 - \beta A)$ is greater than 1. In oscillators β is positive at one frequency, at least, so that the A_0 is greater than A . In the particular case where $A = 1$, the gain $A_0 = \frac{A}{0} = \infty$ and this is

interpreted as the onset of oscillation. If the feedback is overdone—or the gain, A , too large—so

that $(1 - \beta A)$ becomes negative, A_0 becomes negative and the exact interpretation of this depends on the exact circuit. Usually what happens is that the amplitude of oscillation grows until the amplifier saturates and violent distortion results.

Consider now the amplifier characteristic of Fig. 2. This curve represents the overall input-output characteristic of a hypothetical amplifier before RC feedback is applied. A little thought convinces one that the gain of the amplifier is merely the slope of the curve which, for the purposes of illustration, is shown as rather more variable than is generally the case in practice. Three tangents have been drawn to the curve at P, Q, and S, corresponding to the three gains A_1 , A_2 , and A_3 , at the three output amplitudes V_1 , V_2 , and V_3 . Now suppose that the gain required to make $\beta A = 1$ in a particular oscillator lies between A_1 and A_2 , then the output amplitude will lie between V_1 and V_2 . As the amplifier characteristic is nearly straight over the OQ region of the curve, little distortion would be expected. But if the value of A for oscillation happened to fall between A_2 and A_3 , then a larger amplitude of oscillation would be expected

of maintaining the amplitude of oscillation at a level sufficiently large to be useful, but sufficiently small to keep distortion within tolerable limits—say less than one per cent.

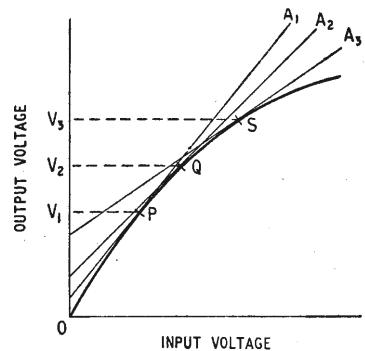

Fig. 2. Hypothetical amplifier characteristic.

The obvious way of controlling the amplitude of oscillation is to control the gain of the amplifier, and this leads one naturally to think in terms of variable- μ valves. Unfortunately these are not very suitable for the purpose as only a limited amplitude can be handled by such valves without incurring distortion, owing to the necessarily curved valve characteristics. A better alternative is to control the gain of the amplifier, or the feedback factor β , by means of a resistive element whose resistance is dependent on the amplitude of the applied voltage. Examples of such elements are lamp filaments, and "thermistors" which are now available commercially.

Fig. 3 shows a typical oscillator¹ in which the RC network is a Wien bridge, and the amplitude control is normally carried out by using a thermistor for R_1 , or a lamp

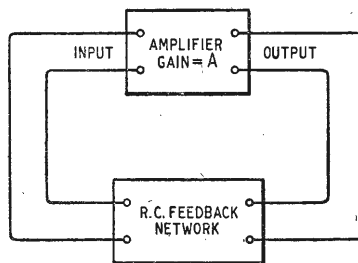

Fig. 1. Block diagram of an RC oscillator.

with a corresponding increase in distortion. As in all oscillators, therefore, means must be found

¹ Terman, "Radio Engineer's Handbook" 1st Edn., p.505. McGraw-Hill.
Terman, Buss, Hewlett & Cahill. Proc. I.R.E. Vol. 10, p.649. Oct. 1939.
Brit. Pat. No. 489,849.

for R_2 . The conditions for balance in the Wien bridge are

$$2\pi f_0 RC = 1 \text{ or } f_0 = \frac{1}{2\pi RC}$$

and

$$\frac{R_2}{R_1 + R_2} = \frac{1}{n} = \frac{1}{3}$$

But if the bridge were exactly balanced there would be no feedback from output to input at the required frequency of oscillation, f_0 . Analysis shows that in fact the bridge must be slightly off balance for the circuit to oscillate, and if there is no phase shift in the amplifier, the conditions for oscillation $(1 - \beta A) = 0$ are

$$f_0 = \frac{1}{2\pi RC} \text{ as before}$$

$$\text{and } \frac{1}{n} = \frac{1 - 3/A}{3} = \frac{R_2}{R_1 + R_2}$$

The former condition is obviously the one which controls the frequency of oscillation, and the latter offers the possibility of controlling the gain by the automatic variation of R_1 or R_2 with amplitude.

As R_2 forms the cathode bias resistor of the first amplifier valve, in addition to being one arm of the bridge, its value is restricted to a particular range according to the valve type chosen. R_1 must then be approximately twice

condenser C_B has to be made of very large value—8 or $16\mu\text{F}$ —in order to avoid undesirable phase shifts in the amplifier at low frequencies.

As already noted, if a filament lamp is used for R_2 , automatic control of amplitude can be achieved, because as the amplitude of the RC oscillation signal fed through C_B increases, so also does the resistance of the lamp.

In consequence if $\frac{1}{n}$ is initially considerably less than $1/3$, as the amplitude rises the value of

Fig. 4. Typical lamp and thermistor characteristics.

$1/n$ increases, until at some particular amplitude it becomes equal to $\frac{1 - 3/A}{3}$, and the amplitude

of oscillation is stabilized. In design, care is taken to ensure that this amplitude is well within the capabilities of the second amplifier valve (having due regard for its low effective anode load) so that distortion is low.

An alternative scheme is to use a thermistor for R_1 , and as the voltage across a thermistor increases, its resistance decreases. As R_1 is only called upon to carry alternating current, the

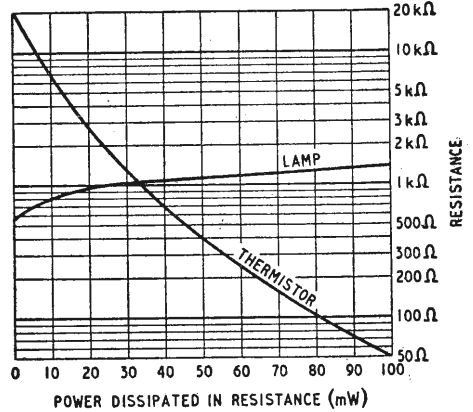

control achieved by using a thermistor here should be rather better, and is, in any case, easier to design.

One point should be watched; the resistance of R_1 and/or R_2 should be constant throughout one cycle of oscillation, or the feedback will not be constant throughout one cycle, and distortion will result. Thus, a lower limit is set to the frequency of oscillation by the thermal time constant of the stabilizing device. The writer has found lamps satisfactory down to about 20 c/s, and thermistors to about 10 c/s, although the exact figure will depend on the tolerable distortion and the exact components used. Fig. 4 shows curves of resistance against power dissipated for a 15-watt, 240-volt lamp, and for a S.T.C. thermistor No. A2451/100.*

Distortion is further reduced in this particular oscillator by the fact that with increasing order of harmonic, the amplifier is subject to increasing negative feedback so that the effective gain at harmonic frequencies is progressively reduced. This is a considerable help in attaining freedom from distortion.

* Reference to thermistor curves of resistance/voltage shows that for many values of applied voltage there are two possible values of resistance. The lower value of resistance is the one to choose, and to put the component in this state the circuit must be capable of supplying momentarily the maximum voltage shown by the resistance/voltage curve. Such a curve may be computed from the manufacturer's curve given in Fig. 4.

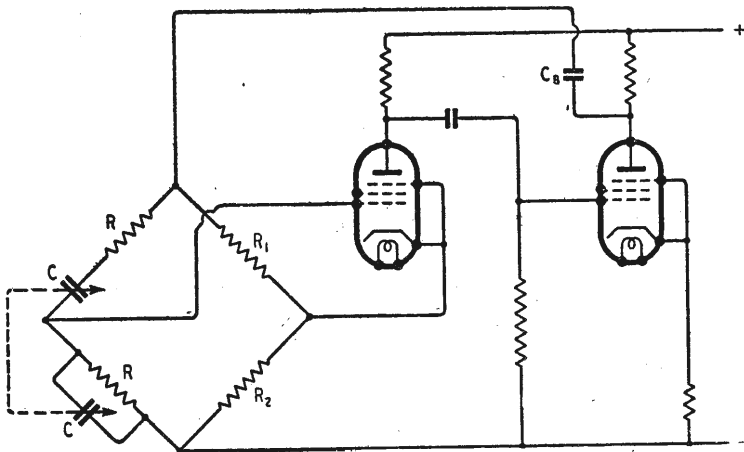

Fig. 3. Wien bridge RC oscillator.

R_2 in order that $1/n$ shall be approximately $1/3$, and as cathode bias resistors are notoriously low in value, the load on the second valve must also be low. Hence a power valve is commonly used in this position, and the blocking

Stabilization by this method is rather complicated by the fact that d.c. flows through R_2 and the first valve, as well as a.c. through R_1 and R_2 , although it is only this latter which is effective in stabilizing the amplitude.

Electronic Circuitry—

THE cathode-coupled amplifier, is now in wide use, and it is the practice sometimes to introduce variable gain^a by means of a resistance R_v bridging the two cathodes each of which is then returned to negative h.t. through its own resistor R_k , as shown in Fig. 5. As long as push-pull input is applied a balanced push-pull output is obtained whatever the value of R_v , and each valve

Cathode-coupled Amplifiers

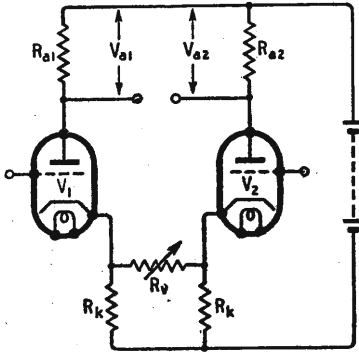

Fig. 5. Cathode-coupled amplifier with variable gain.

behaves as if it had a cathode feedback resistor of value equal to the resistance of $R_v/2$ in parallel with R_k .

But now consider the same circuit in phase-splitter service. Under these conditions both grids are returned to the same positive

$$A_2 = \frac{\mu R_{a2}}{\left[(R_{a2} + r_a) (2 + R_v/R_k) + (\mu + 1) (R_k + R_v) \right] \left[\frac{R_{a1} + r_a}{(\mu + 1) R_k} + \frac{1 + R_v/R_k}{2 + R_v/R_k} \right] - \frac{(\mu + 1) R_k}{2 + R_v/R_k}} \dots \dots (3)$$

bias potential, but the signal is fed into only one grid—say that of V_1 . When $R_v = 0$ the two resistors R_k are directly in parallel and form the familiar cathode coupling resistor. But consider what happens as R_v is increased indefinitely and eventually made open-circuit. No signal then reaches either cathode or grid of V_2 so that its output and gain fall to zero; at the same time a small gain is obtained from

V_1 , and the two outputs at the anodes are completely unbalanced. If R_v is greater than zero the unbalance will still be present to a greater or lesser extent, and as R_v is reduced again to zero the unbalance decreases until only the inevitable unbalance of a cathode-coupled amplifier is left (i.e., when the anode loads are equal.) This remanent unbalance of the two output voltages may be rectified by making the anode loads unequal, and indeed by this means balance can be achieved for any reasonable value of R_v — but only for one value.

On analysis it turns out that the ratio of the output voltages for phase-splitter service is

$$V_{a2}/V_{a1} = \frac{(\mu + 1) R_k}{(R_{a2} + r_a) (2 + R_v/R_k) + (\mu + 1) (R_k + R_v)} \cdot \frac{R_{a2}}{R_{a1}} \dots (1)$$

For any particular setting of R_v exact balance can be obtained by making $R_{a1} < R_{a2}$, and the condition for exact balance is

$$R_{a1} = \frac{R_{a2}}{1 + R_v/R_k + \frac{(R_{a2} + r_a)(2 + R_v/R_k)}{(\mu + 1) R_k}} \dots \dots (2)$$

where r_a = anode resistance and μ = amplification factor of either valve. The analytical expression for the gain from the input grid to either anode becomes rather tedious to work out (and rather formidable in use) as soon as feedback is introduced by R_v . The gain from the grid of V_1 to the anode of V_2 is given by

The gain — A_1 —to the first anode can be found by calculating A_2 by (3) and modifying the result in the light of (1) which represents the ratio of the two gains as well as the ratio of the output voltages.

Generally speaking this form of variable gain is best restricted to stages driven in push-pull whenever it is important to maintain an exact balance. Very often, however, a reasonable approximation to balance can be maintained in a variable gain phase-splitter circuit, provided the gain is only varied between fairly narrow limits.

LIGHTWEIGHT TELEWRITER

Tone Operation Over Line or Radio Channel

UNDER the auspices of British Telecommunications Research, Ltd., Derwent House, Arundel Street, London, W.C.2, there was demonstrated recently a novel lightweight teleprinter of Swiss manufacture and known as the ETK Telewriter.

The complete machine measures 15x13x6 in, weighs 26 lb and has many commercial applications. With the addition of a 1,500-c/s tone generator it can be operated over telephone circuits, but where a d.c. circuit exists this attachment is not necessary.

As it can be operated with tone signals the machine is also suitable for use over any radio link provided high-speed operation is not essen-

tial. The present design of machine is capable of 35 words per minute, sending and writing. With the addition of ciphering equipment the signals passed to the line are scrambled and a very high degree of secrecy is obtained.

An interesting feature of this machine is that the characters are not typed in the accepted sense, but are built up from a number of

elementary signs. There are fourteen such signs on the typing head and those required to form a particular letter or character are selected by the sequence of the received signals. Five parts generally suffice to form a single character. Synchronization between the send and receive machines is effected by a new design of governor.

"Making the most of your Receiver" is the title of a 12-page booklet issued by Stratton and Co. Ltd., Alvechurch Road, West Heath, Birmingham 31. It gives helpful advice on the choice and erection of aerials, the suppression of electrical interference, the care of batteries, and hints on loudspeakers and headphones. The price is 1s.

^a Puckle, O. S. "Time Bases." 1st Edn. p. 121. Chapman & Hall. Jofeh, M. L. Brit. Pat. No. 529,044

Vortexion

SUPER FIFTY WATT

This **AMPLIFIER** has a response of 30 c/s. to 25,000 c/s. within $\frac{1}{2}$ db, under 2 per cent distortion at 40 watts and 1 per cent at 15 watts, including noise and distortion of pre-amplifier and microphone transformer. Electronic mixing for microphone and gramophone of either high or low impedance with top and bass controls. Output for 15/250 ohms with generous voice coil feedback to minimise speaker distortion. New style easy access steel case gives recessed controls, making transport safe and easy. Exceedingly well ventilated for long life. Amplifier complete in steel case, with built-in 15 ohm mu-metal shielded microphone transformer, tropical finish.

As illustrated. Price **36½ Gns.**

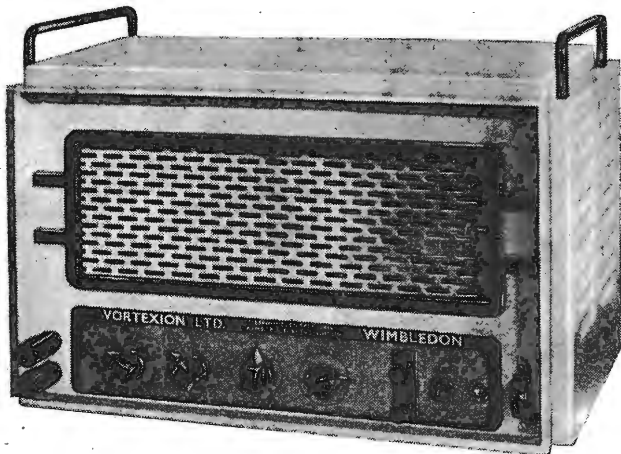

CP20A. 15 WATT AMPLIFIER

for 12 volt battery and A.C. Mains operation. This improved version has switch change-over from A.C. to D.C. and "stand by" positions and only consumes $5\frac{1}{2}$ amperes from 12 volt battery. Fitted mu-metal shielded microphone transformer for 15 ohm microphone, and provision for crystal or moving iron pick-up with tone control for bass and top and outputs for 7.5 and 15 ohms. Complete in steel case with valves.

As illustrated. Price **£28 0 0.**

30 WATT RECORD REPRODUCER

This amplifier has been produced for extremely high quality gramophone or microphone quality in large halls or in the open. An output power of 30 watts is obtainable at under 1% distortion after the output transformer which is arranged for 4, 7½, or 15 ohm output. The most noticeable point is the absence of background noise or hum.

Very generous feedback is employed to help out any distortion developed by the speaker and the large damping factor ensures good transient response. The usual response of 30 to 25,000 cycles plus or minus $\frac{1}{2}$ db is given, and recording compensation of 5 db per octave lift below 300 cycles is obtainable on the gramophone input by means of a switch. A carefully balanced treble control is arranged to correct top lift on some recordings as well as to reduce scratch on old records without noticeable effect on frequencies below 3,500 to 4,000 cycles. The input is intended for the high fidelity type of pick-up and is fully loaded by an input of .2 volts on 100,000 ohm or $\frac{1}{4}$ meg. ohm as required. The microphone stage requires an input of .3 millivolts on 15 ohm balanced line through the wide response mumetal shielded microphone transformer. An octal socket is fitted at the rear of the chassis to provide power for feeder units, etc., 6.3 volts at 2 amps and 350 volts at 30 milliamps is available.

Complete in well ventilated steel case. Price **30½ Gns.**

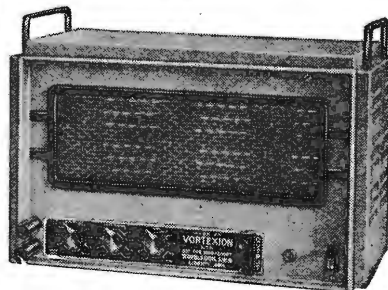

EXPORT

Enquiries from Overseas will receive prompt attention. Continental Buyers are invited to get into touch with our Belgian Agents:

Ms. Constant L. Bismar,
129 Avenue de la Reine,
Téléh. 16.10.31. Bruxelles

FOUR WAY ELECTRONIC MIXER

This unit has 4 built-in, balanced and screened microphone transformers, normally of 15-30 ohms impedance. It has 5 valves and selenium rectifier supplied by its own built-in screened power pack: consumption 20 watts. Suitable for recording and dubbing, or large P.A. Installations since it will drive up to six of our 50 watt amplifiers, whose base dimensions it matches. The standard model has an output impedance of 20,000 ohms or less, and any impedance can be supplied to order. Price in case with valves, etc., **£24.**

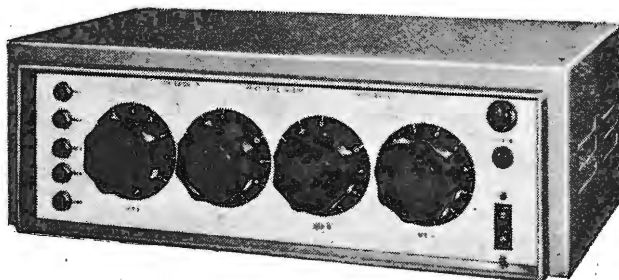

VORTEXION LIMITED, 257-261 THE BROADWAY, WIMBLEDON, LONDON, S.W.19
Telephones: LIB 2814 and 6242-3
Telegrams: "Vortexion, Wimble, London"

Simon

SOUND SERVICE

THE COMPLETE SERVICE
FOR SOUND RECORDING AND
REPRODUCTION



- ★ Mobile, static and specialised recording units
- ★ Recording amplifiers, speakers, microphones, etc.
- ★ Sapphire cutting and reproducing stylii
- ★ Blank recording discs from 5in. to 17in. Single and Double-sided
- ★ Groove locating and cueing devices
- ★ A comprehensive range of accessories to meet every requirement of the sound recording engineer
- ★★ A development of special interest to users of sapphire and delicate pick-ups—THE SIMITROL. This is a controlled micro-movement easily fitted for use with any type of pick-up
- ★★★ OUR CDR49A RECORDER UNIT complete and self-contained, measuring only 22in. x 14in. x 13½in., incorporating 8-valve amplifier, recorder unit, lightweight pick-up, speaker and microphone and with many exclusive features, is now ready for early delivery

Portable
Twin channel Continuous
Recording system incorporating
CDR49A Recorder/Amplifier
DR49A Recorder and EM49A Electronic
4 Channel Mixer
Manufactured exclusively by
Simon Sound Service.

OUR WELL-EQUIPPED WORKSHOPS ARE AVAILABLE FOR THE
DEVELOPMENT OF EQUIPMENT TO MEET SPECIAL NEEDS.

SIMON SOUND SERVICE, Recorder House, 48/50, George St., Portman Square, London, W.1.

CABLES : Simsale, London.

TELEGRAMS : Simsale, Wesdo, London

TELEPHONE : Welbeck 2371 (4 Lines)



PLAN YOUR CAREER

RADIO • TELEVISION
and other INDUSTRIAL
ELECTRONIC subjects
ELEMENTARY & ADVANCED COURSES

WRITE FOR FREE BOOKLET summarising careers available in Electronics and giving particulars of Courses offered by E.M.I. Institutes.

The booklet contains full details of elementary and advanced HOME STUDY and DAYTIME courses in Radio, Television, Telecommunications and Industrial Electronics.

Courses ideal for those seeking recognised qualifications are also available.

Payment for tuition can be made in easy instalments if required.

Write to Dept. 16A

E.M.I. INSTITUTES

43, GROVE PARK ROAD, LONDON, W.4. CHiswick 4417/8

Associated with
"H.M.V."
MARCONIPHONE
COLUMBIA
ETC.

CO-AX AIR-SPACED ARTICULATED R.F. CABLES

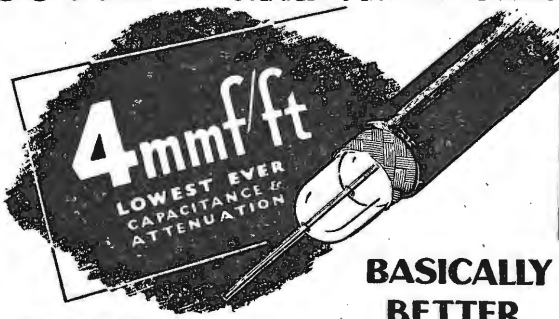

BASICALLY BETTER

IMMEDIATE DELIVERIES
FOR HOME & EXPORT

LOW ATTEN. TYPES	IMPED OHMS	ATTEN. db/100ft at 100 Mc/s	LOADING K _{in}	O.D.
A.1	74	1.7	0.11	0.36
A.2	74	1.3	0.24	0.44
A.34	73	0.6	1.5	0.85

HIGH POWER FLEXIBLE

FOR RADIO FREQUENCIES

LOW CAPAC. TYPES	CAPAC. mm ² /ft	IMPED OHMS	ATTEN. db/100ft 100 Mc/s	O.D.
C.1	7.3	150	2.5	0.36
P.C.1	10.2	132	3.1	0.36
C.11	6.3	173	3.2	0.36
C.2	6.3	171	2.15	0.44
C.22	5.5	184	2.8	0.44
C.3	5.4	197	1.9	0.64
C.33	4.8	220	2.4	0.64
C.44	4.1	252	2.1	1.03

PHOTOCELL CABLE

FOR VIDEO and SPECIAL APPLICATIONS

VERY LOW CAPACITANCE CABLES

Write for data sheets to the originators of air-spaced R.F. Cables.

TRANSRADIO LTD. 138 & CROMWELL ROAD LONDON S.W.7.
CONTRACTORS TO H.M. GOVERNMENT.

GENERALIZED GRAPHS

Their Derivation and Use in Design Calculations

By "CATHODE RAY"

ALGEBRA is still so badly taught that most school children see in it exactly the opposite of what it really is—a device for minimizing brain work and saving time. Working out a problem by arithmetic gives the answer only for the particular numbers or values or dimensions concerned; doing it by algebra gives a result that covers all problems of that kind, the answer for any particular numbers being obtained simply by substituting them for the letters. As the textbooks put it, algebra is generalized arithmetic. The information that a tuned circuit

3-V sinusoidal input is applied to an amplifier coupling consisting of $0.01\mu\text{F}$ in series and $0.5\text{M}\Omega$ in parallel. The extent to which the output falls off at low frequencies is much more clearly displayed in this way than by a collection of figures. If the performance

to have a wide range of different voltages applied to it at different times, or even at the same time. So far as we can tell, 3V has no special merit or significance, except that it is more convenient than (say) 2.9307V. But 1V or 10V or 100V would be more convenient still. Why?

indicated by this graph is just what one wants—or at least what one is willing to tolerate—then it as good as says "Go ahead; use $0.01\mu\text{F}$ and $0.5\text{M}\Omega$."

Unfortunately it says nothing about what to do if we happen to have only a $0.005\mu\text{F}$ capacitor, or if we want less loss at 25 c/s, or even what output we would get at 25 c/s if the input were 2V instead of 3V. A graph of this

Voltage Ratios

The reason is interesting: it is because the output could then more easily be read as a decimal fraction or percentage of the input. What we usually want to know about amplifiers and similar arrangements is not the actual voltage output but the relative voltage or percentage gain or loss. This, of course, is on the assumption that the output voltage is directly proportional to the input. Up to a point that is usually correct. The only occasions when one is interested in the actual voltages is when that

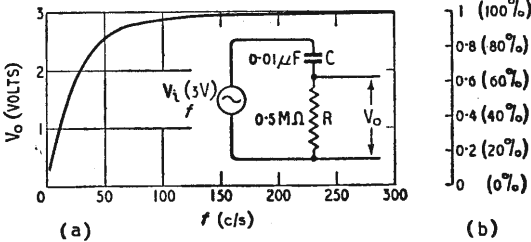

Fig. 1. Example of a graph showing a relationship (output voltage against input frequency) confined to certain stated conditions (see inset circuit diagram). It can be made slightly more general by dividing the V_o figures by V_i , so that the vertical scale is as at (b).

having an inductance of 160 microhenries and a capacitance of 250 picofarads will resonate at a frequency of 796 kilocycles per second is not much help if the tuned circuit in which one is interested does not happen by some remarkable coincidence to have an inductance of 160 microhenries and a capacitance of 250 picofarads. But once the fact that $f_r = 1/2\pi\sqrt{LC}$ has been established it enables the resonant frequency for all possible values of inductance and capacitance to be found without any serious or prolonged effort.

A Particular Graph

Graphs are another very helpful way of recording and conveying information. Fig. 1(a) for example shows how the output voltage is affected by frequency when a

sort is like arithmetic; it is very explicit about one particular case but reticent about all others.

So persons (including your humble servant) who are more concerned with conveying general principles than isolated data naturally look for a graphical counterpart of algebra. But just as algebra mystifies the uninitiated and requires some slight mental effort to apply to particular cases, so generalized graphs are perhaps less used than they might be for fear that they might not be understood. I hope that what follows may help to allay such fears.

Having examined Fig. 1(a) as an example of an ungeneralized (or particular) graph, we might as well keep on with it and see how it can be generalized.

The most annoyingly particular thing about it is the input voltage. An amplifier coupling is likely

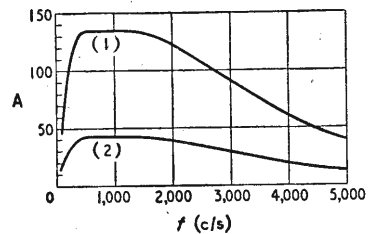

Fig. 2. When amplifier characteristics are plotted with linear amplification and frequency scales, as here, it is difficult to compare their merits.

point is exceeded, by the valves' being driven into grid current or in some other way. In our simple Fig. 1 circuit at any reasonable voltage that sort of contingency is hardly likely to arise.

So a first step in generalization is to make the vertical scale read V_o/V_i , the ratio of output to input voltage, which we can if we

Generalized Graphs—

like denote by a single letter such as A (Fig. 1(b)).

With many simple combinations of circuit elements, such as in Fig. 1, the output tends to equal the input at some part of the frequency range. So the

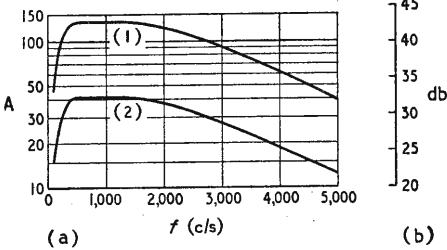

Fig. 3. The Fig. 2 curves have here been plotted with a logarithmic voltage-amplification scale, which brings out the fact that their frequency characteristics are identical, the only difference being amplification level. An alternative to the logarithmic A scale is the linear decibel scale (b). Aurally the range of frequency from 100 to 400 is as great as from 1000 to 4000, but the linear frequency scale distorts this proportion, and is a hindrance to further generalization.

new scale directly indicates the percentage at other frequencies, relative to this "ideal" level. But in a complete amplifier the "ideal" level might be almost any figure, so it would be less easy to make the comparison. Curve (1) in Fig. 2 is an example. The voltage gain is practically level at 135 over the range of frequencies around 1000 c/s, and at 4000 c/s is down to 60. To find the relative level at 4000 c/s it is necessary to divide 60 by 135. Of course the whole scale could be divided by 135 (or 1.35), making the flat top read 1 (or 100) and a note added to the effect that the actual voltage gain here was 135. But there is not always an obvious comparison level such as this, and, even where there is, one may want to compare the levels at two other points. Curve (1) doctored to make the flat top 100%, for example, would be no better than the original curve for comparing the output at 5000 c/s with that at 3500 c/s.

And look at curve (2), relating to another amplifier. So far as constancy of output with frequency is concerned, is it better or worse than amplifier (1)? At first glance it certainly looks

"flatter"; but you will find that the relative loss at all frequencies is exactly the same.

It would be helpful if any given vertical distance on the graph represented the same voltage ratio, whether it was at a high level, such as curve (1), or a low level such as (2). Then the effect of increasing the overall voltage gain of an amplifier would be to shift its curve bodily upwards without altering its shape. What is wrong with the scale in Fig. 2 is that a rise from 10 to 20, which is 100% increase, looks the same as a rise from 100 to 110, which is only 10% increase.

In Fig. 3(a) the vertical scale has been redistributed so as to make a 100% increase (or any other percentage increase or decrease) occupy the same distance from every starting point. It is as far from 10 to 20, for example, as from 50 to 100, and 75 to 150. Replotted on this scale, curves (1) and (2) are identical in shape and differ only in level; which is a fairer representation of the facts than Fig. 2. The scale, of course, is the well-known logarithmic variety, seen on every slide-rule. The only thing still wrong with it is that it is not uniform and so is difficult to interpolate (i.e., read between the marked divisions). It is quite easy to make it into a uniform scale, because by definition it was a scale in which any given voltage ratio occupied the same distance everywhere along it. So we could measure off the distance between 10 and 11 (or 100 and 110, which would be exactly the same), and make a new scale in which the marks would be evenly spaced by this distance. They could then be numbered 1, 2, 3, etc., "ten-per-cent-increases."

Decibels

If the voltage gain anywhere were, say, 400, the addition of two ten-per-cent-increases would no more make it 480 than two similar successive rises in your salary of £400 would bring it to £480. The answer, as you would no doubt be very quick to point

out if the accountant made the mistake, is £400 × 1.10 × 1.10 = £484. It would be quite feasible to make out a table connecting the scale in ten-per-cent-increase units with the voltage gain scale, for convenience when one wanted to know the actual voltage gain represented by a given vertical distance. But a disadvantage of the ten-per-cent-increase as a unit (in addition to its inelegant name) is that no whole number of them equals a convenient ratio such as 10 : 1. So the matter was actually tackled from the other end, by taking the 10 : 1 ratio and dividing it into ten "x-per-cent-increases," which were named decibels. x was then found to be 25.9...%

Since adding 10 db is the same as multiplying by 10, adding a second 10 db, making 20, raises the 10 to 100. And so on. This system was devised by people

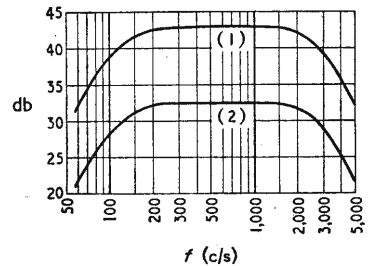

Fig. 4. Here the same two curves are revealed in their proper proportions in both dimensions (compare Fig. 2).

who were more concerned with power than voltage, so they took as its basis a 10 : 1 power ratio,— a fact one should never forget when using decibels. But provided that the impedance is the same, power is proportional to voltage-squared, so a 10 : 1 voltage ratio corresponds to a 100 : 1 power ratio. We have seen that a 100 : 1 power ratio is 20 db, so a 10 : 1 voltage ratio is also 20 db. 10 db is a voltage ratio of $\sqrt{10} : 1$ (3.16... : 1). We converted our Fig. 1(a) graph into a voltage ratio graph at a very early stage, so it is quite suitable for having a db scale attached to it.

The other main thing to remember about db is that they are ratios, not actual voltages or powers. The only way in which a number of db can mean a voltage or power is when it has been

stipulated that zero db represents some specified voltage or power.

So much for the vertical scale. What about the frequency scale? We have been using a perfectly straightforward kind in which 1 inch represents so many c/s. With radio frequencies this is often the best thing to do, because modulation of a carrier wave causes it to occupy the same number of c/s regardless of where the carrier frequency may come on the scale. But with audio frequencies it is generally the ratio that counts, rather than the actual number. A frequency ratio of 1.122:1 is recognized by any except hopelessly unmusical ears, whether it is in the low, middle or high-note region, representing respectively a frequency range of 20, 50, or 200 c/s. Musicians call it a whole tone, and by an interesting coincidence it is almost exactly the same ratio as 1 db on the voltage scale. From this point of view, then, we would again adopt a logarithmic scale; but instead of dividing it up into db we could divide it into musical tones, 6 of which equal one octave (or 2:1 ratio). In actual fact the slope of a curve is quite often expressed as, say, 12 db per octave. But the scale itself is usually drawn on a 10:1 ratio basis, like the vertical scale, except that instead of being divided uniformly into units corresponding to db it is generally left in non-uniform c/s as in Fig. 4.

There is another reason why it is a good idea to make frequency scales logarithmic. Fig. 1 referred

made one step more general by saying that RC is $0.005 M\Omega \mu F$. For in that circuit, V_0/V_i at any particular frequency depends on R multiplied by C, so whatever R may be one can find a value of C that will make the curve apply. But it would be more useful still if it could answer such questions as "How much is it necessary to increase RC in order to ensure that the response is not less than 90% at all frequencies from 50c/s upwards?"

As it happens, V_0/V_i is determined by the product RfC . From Fig. 1 (a) (or more easily if it were provided with a scale of V_0/V_i rather than V_0) it can be seen that the lowest frequency at which $V_0/V_i = 0.9$ is 66c/s. To leave V_0/V_i and therefore RfC unaltered when f is reduced from 66c/s to 50c/s it is necessary to increase RC in the ratio 66:50, which of course can be done by increasing R or C or both. All this can be simplified by plotting V_0/V_i against RfC in the first place, giving a universal or generalized graph for this particular circuit (Fig. 5). Then all one has to do to make it fit any particular problem, such as the design of a tone control, is to decide whereabouts on the curve any one frequency should come. Suppose that at 20c/s V_0/V_i ought to be 0.2. Fig. 5 shows that the point is at 0.035 on the RfC scale, so RC must be $0.035/20 = 0.00175$; say $0.005 \mu F$ and $0.35 M\Omega$. By dividing the RfC scale by 0.00175 it is converted into a frequency scale for this particular case.

The process just described may not seem much of a simplification; but consider the alternative of drawing a whole lot of particular curves with different frequency scales until one turns up that fits the require-

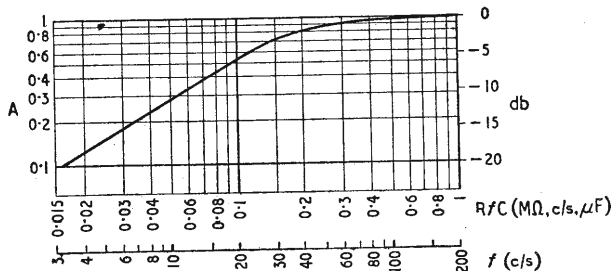
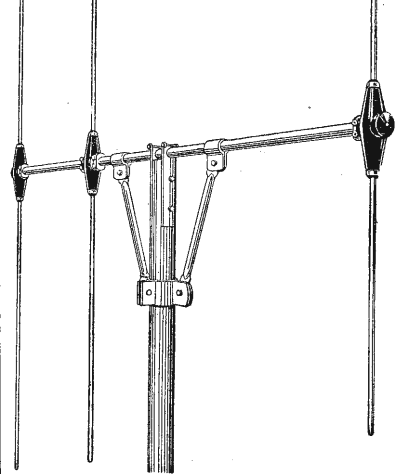

Fig. 5. The same change of scales is applied here to Fig. 1, with the frequency scale generalized by dividing the original figures by RC. If a loose frequency scale (such as the one below the RfC scale) is slid along until the desired characteristic is obtained, the ratio of the two scale readings at any point gives the necessary value of RC.

to a circuit in which R was $0.5 M\Omega$ and C was $0.01 \mu F$. Even as drawn there the curve can be

used for all calculations of this kind. More-

THE ANTIFERENCE D.5. THREE ELEMENT TELEVISION AERIAL



FOR LONG RANGE RECEPTION All connections enclosed and sealed against corrosion

The D.5 Aerial is designed for Television reception at long range. In addition to the normal dipole and reflector rods, a third element—the Director—is mounted on the supporting arm and positioned between the dipole and the transmitting station. The addition of this director element results in extra gain of signal and much improved directional properties. The aerial may also be used in stronger signal areas where extra directivity is required to eliminate ghost images or to minimize interference.

The Antiference Junction Units (Prov. Pat.) provide ample support for the aerial rods and a high degree of insulation in all weathers. All electrical connections are completely weathertight, preventing any possible deterioration in performance. The adjustable mast cap enables any size mast to be used, but a minimum of 2½ in. diameter is recommended. Mast mounting brackets are available for either lashing to a chimney (LSG/2) or bolting to any flat surface (SMB/2). The signal gain of the D.5 Aerial compared with that of a standard dipole is approximately 7dB (2-1).

Cat. No. for London D5. LIST PRICE £6.
Cat. No. for B'ham D5/B. LIST PRICE £6.

ANTIFERENCE
LIMITED
67 BRYANSTON ST., LONDON, W.1.

Generalized Graphs—

over, by making the horizontal scale logarithmic as in Fig. 5, one can slide a loose frequency scale along it until the curve comes in the right place. The ratio of any RfC reading on the fixed scale to the f reading on the sliding scale at the same point gives the required RC at once. This would not work with any other than a logarithmic scale.

A slight modification of this method of dealing with the horizontal scale in cases like Fig. 5 is sometimes to be preferred, especially for purposes of comparison, and it ties up better with the algebraical approach. Although frequency is the variable that most of us use in practice, the more fundamental quantity in theory is $2\pi f$, denoted by ω . So one could plot the curve against $R\omega C$ instead of RfC . To change from Fig. 5, all the numbers on the horizontal scale would have to be multiplied by 2π , or (what comes to the same thing) the scale could be moved bodily to the left, sufficiently for 1 to occupy the place now held by $1/2\pi$ or 0.159.

This merit of this scheme, which may not be obvious at the moment, is revealed by considering how the curve is actually arrived at. The ratio V_o/V_i is, of course, the ratio of R to the impedance of R and C in series.

$$\begin{aligned} \text{So } V_o/V_i = A &= \frac{R}{\sqrt{R^2 + X_c^2}} \\ &= \frac{1}{\sqrt{1 + X_c^2/R^2}} \\ &= \frac{1}{\sqrt{1 + k^2}} \end{aligned}$$

in which k denotes X_c/R .

In this simple way we have reduced the variables from three

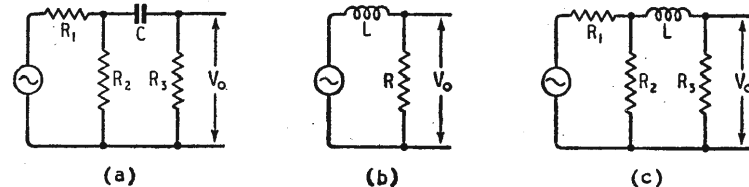

Fig. 6. Examples of circuits to which a curve of the shape shown in Fig. 5 can be made to apply by substituting appropriate variables for RfC .

(R , C and f) to one (k), which is the ratio of reactance to resistance in the circuit. Now $1/k$ is R/X_c or $R\omega C$, which is what we have

thought of plotting A against. It is true that at some stage we may have to unpack the parcel k again in order to get at the contents, R , C and f , but in the meantime we should have gained a clearer view of the relationships in the circuit with which we began, in Fig. 1. And what makes this more worth while is that this same curve, defined by

$$A = 1/\sqrt{1 + k^2},$$

applies to a number of other circuits, such as those shown in Fig. 6, if the parcel k is made up of the appropriate contents. (This is one of the things that is much easier to see with the help of Thévenin's theorem.)

Another advantage of the k scale is that the good round number 1 on it corresponds to a halving of the power in the circuit and so makes a useful reference point or basis for comparison. Half-power is $1/\sqrt{2}$ voltage, so A at this point is $1/\sqrt{2} = 0.707$ or roughly 70%. This happens to be the point at

Fig. 7. Plotting V_o/V_i against f for various values of L , C and R , one can get an infinite variety of curves, of which a few are shown here. But by choosing different scales they can all be reduced to a single curve; see Fig. 8.

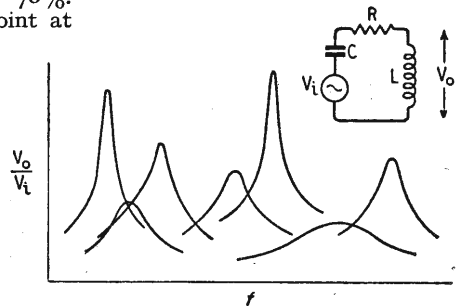

which a fall-off in sound power generally begins to be noticeable. It is very easy to remember that it occurs at the frequency for which k (which = $2\pi fRC$) is equal to 1; so, if you decide what frequency it should be, the product RC follows.

interchanged. Again, the frequency which makes the ratio of X_c to R equal to 1, marks the noticeable fall-off. The frequency range between these two reference marks defines the effective bandwidth of the amplifier.

Generalized Resonance Curves

There are a number of other commonly - encountered design problems in which a single curve can be made to cover the entire range of values. One class of them is the resonance or selectivity curve. Take the simplest case—a single tuned circuit. Its response depends on L , C and R . Filling in different values for these, one could get an infinite variety of resonance curves, some sharp, some flat, some resonating at high frequencies, some at low, and so forth (Fig. 7). Yet the chances are that not one of them would

exactly fit a particular requirement. If it came at the right frequency it might be too sharp or too flat, or vice versa. But by plotting with suitable scales a single curve can be made to cover all possible combinations of L , C and R . Another curve covers all combinations of two tuned circuits with a specified degree of coupling; and so on.

First of all the peaks of the separate (Fig. 7) curves are all brought to a common level by reckoning V_o relative to V_{or} (V_o at resonance) instead of to V_i . Next, they are brought to the same point horizontally by plotting V_o/V_{or} against a " k " defined as Qf/f_r , where f is the frequency off-tune and f_r is the frequency at resonance. By this dodge the differing sharpnesses or flatnesses are combined in one curve, because the frequency at which a given

fall-off takes place is inversely proportional to the tuning circuit.

The result is given in Fig. 8 for a single tuned circuit and also for

frequency at that (or any other) point, the Q of the circuits for any given resonant frequency automatically follows.

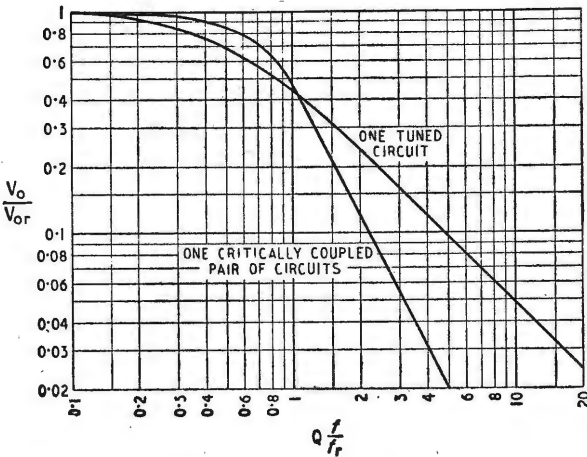

Fig. 8. Here V_o and f , are respectively the output voltage and frequency at resonance, and by using them as the basis of comparison, and incorporating R in Q, the multiplicity of Fig. 7 curves reduces to one. Other tuning systems can each be represented by one curve, and their essential characteristics compared.

a pair of critically coupled circuits. These show at once that the pair of circuits gives more level response near resonance than the single circuit, and at the same time gives better selectivity beyond a certain point ($Qf/f_r = 1.1$) where the two curves intersect. By deciding on the off-tune fre-

quency at that (or any other) point, the Q of the circuits for any given resonant frequency automatically follows. Suppose we make it 5kc/s, and the carrier frequency is 600kc/s. Then $Q = 1.1 \times 600/5 = 132$. Similar curves can be worked out for standard forms of filter circuit, in which the variable frequency is generally reckoned relative to the cut-off frequency. In time one gets to know the shapes of the curves for the most used circuits, and this leads to a much clearer mental picture of how the various quantities involved are related to one another than does a mass of particular-value curves for each type of circuit. That is exactly where algebra scores over arithmetic, of course. And it also seems to be where we came in.

MAINS-BATTERY PORTABLE

THE new Ekco "Stroller" is a lightweight all-purpose receiver which will operate from a.c. or d.c. mains, or from dry batteries.

Mullard D90 series miniature

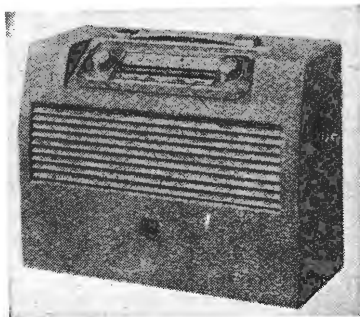

Three wavebands, including 19-51 metres, are covered by the self-contained Ekco Model MBP99 mains-battery portable.

valves with B7G bases are used in the four-valve superhet. circuit; a selenium rectifier is used for the power supply on a.c. mains. Change-over from mains to battery is effected by double-pole switching and all necessary precautions have been taken to safeguard against shock. The price of this new set is £19 19s, including tax.

MANUFACTURERS' LITERATURE

Leaflet describing television aerials made by A.B. Metal Products, Great South West Road, Feltham, Middlesex.

Descriptive leaflet dealing with the "Etronic" Model EB428 battery portable, from the Hale Electric Co., Talbot Road, London, W.13.

Leaflets describing SL301 Aircraft Equipment Tester, SL302 MF Beacon Type WBS, and SL101, VHF Multi-channel Communication Equipment, from Marconi's Wireless Telegraph Co., Ltd., Chelmsford, Essex.

Booklet giving details of the Plessey electron microscope, from the Plessey Company, Ilford, Essex.

TRIX

Quality SOUND EQUIPMENT

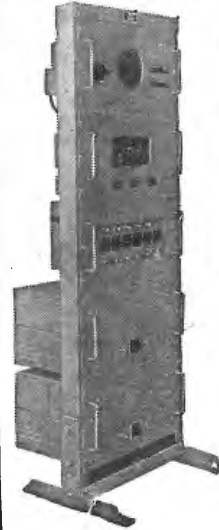

Typical Trix Rack-Mounted Equipment

Rack-mounted equipment for SPORTS GROUNDS, HOSPITALS, FACTORIES, SHIPS, etc. etc.



60 WATT Amplifier . . T663 B.

This amplifier provides the full rated power by the use of four valves in a parallel push-pull output circuit with inverse feedback. It is a high gain 4-stage amplifier which can be used singly or in combination with supplementary units Type T663/S to provide power outputs of 120, 180, 240 watts, or higher.

Where a number of separate inputs are required, our 4-way or 6-way Electronic Mixer can be connected. Like most Trix Amplifiers, the T663B is designed for adaptation to rack mounting.

SEE US AT:-

Stand No.101, Radclyphia

THE TRIX ELECTRICAL CO. LTD
1-5 Maple Place, Tottenham Court Road, London, W.1. Phone: MUSeum 5817
Grams & Cables: "Trixradio, Wesdo. London."

AMPLIFIERS * MICROPHONES * LOUDSPEAKERS

Unbiased

By FREE GRID

Urbi et Orbi

I CANNOT help feeling that we might with some justification set up in this country a body similar to the Academie Française to endeavour to standardize our nomenclature or at any rate attempt to



Bureau of Scientific Nomenclature.

guide it into the right channels. I realize, of course, that some such body must already exist and have given us such excellent terms as capacitance and capacitor, but its terms of reference are obviously not wide enough.

I am moved to make this suggestion by the sudden and increasingly popular use of the term TV. Nowadays we read of TV this and TV that and everybody seems smugly content with this wretched expression. It would not in the least surprise me if I received a shocked letter pointing out that this expression was coined by some sacrosanct body and has received official benediction and that as a result of my remarks my works are being placed on the *Index Expurgatorius* or even *Librorium Prohibitivum*.

My objection to TV and a host of other expressions we use in radio is that, like its parent word television, it does not suggest the idea of radio transmission or radio principles at all. A far better expression, if this craze for abbreviation must be pandered to, would be RV, but it would be better still to use the full word radiovision. Such a word not only keeps the idea of wireless transmission constantly before the minds of the public but would have the advantage of not being an obvious hybrid like television. I do not, however, stress the latter point as the word radio itself is not really an etymological thoroughbred and has only acquired its present meaning by popular usage.

But I am no pedant on the subject of etymological purity, and in particular hybridism, and I don't mind admitting that I think the most suitable term for a television receiver would be "radioscope." I first used it in these columns fifteen years ago; long before Alexandra Palace started operations. Probably, however, this word is more urgently required as a substitute for the wretched expression television camera. This term suggests that television is not a direct transmission but merely a film recording.

But I cannot help feeling that I am a voice crying in the wilderness and that we shall continue to coin our radio expressions in the haphazard fashion that we always have done. Radio is not the only branch of science that does this; has anybody, for instance, heard of a more absurd word than stethoscope to describe the doctor's basic tool? The Bureau of Standard Scientific Nomenclature is indeed badly needed.

Wireless from the Wind

ONE of the most astonishing features of women's mental make-up, which has so far completely baffled the combined psycho-analytical efforts of Freud, Jung and Adler, is their inability to resist buying anything which they fondly and deludedly imagine to be a bargain. Hard-headed business men have not failed to take advantage of this amiable weakness with the result that in the case of most of us the house is littered with useless junk of all sorts.

I pointed this out to a well-known politician the other day and he explained that the Government was well aware of this trait and, with the full agreement of the Opposition, might encourage it as its results were regarded as a fruitful source of salvage. He went even further and stated that if the battle of Waterloo was won on the playing fields of Eton then no less was the battle of the World in 1939-45 won on the domestic dump heaps which women had so assiduously garnered from the bargain counters of our great stores.

Be this as it may, it still did not solve my problem of what to do with the very large accumulation of wind-driven battery charging generators which Mrs. Free Grid recently

secured at a knockout price from a clearance sale. A radio firm had imported large quantities of these devices from the U.S.A. in pre-war days in the vain hope of selling them to country listeners who, having no electricity supply, had to trudge for miles over ploughed fields to get their accumulators charged.

Waste of any kind is against my nature and I could ill afford to lose the amount of money which Mrs. Free Grid had invested in her so-called bargains. I am glad to say, however, I have solved the problem by arranging for these wind-driven generators to supply all power to my wireless gear. It has been a pretty expensive business as the output from these devices is too variable to feed directly to a receiver. It has, therefore, been necessary to collect their output in a battery of costly accumulators. These feed a motor-alternator which supplies power direct to my apparatus.

Unfortunately, the blades of the particular brand of windmill which Mrs. Free Grid bought were made of a light metal alloy which provided ghost images on the television screen. These were moving in more senses than one and I have had to experiment with a very elaborate set of rotating devices which keep exactly in step with the blades and provide a precise 180° out-of-phase

"I pointed this out."

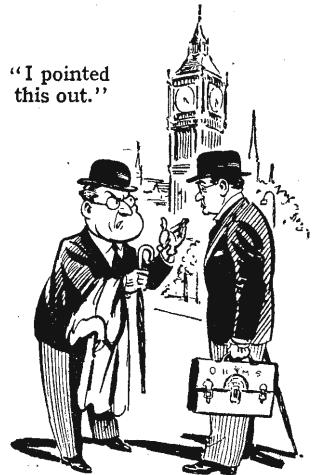

effect. I can say, however, that Mrs. Free Grid's well-meant efforts have not been wasted and next winter my broadcast reception will no longer be governed by the whims of Mr. Gaitskell.

LETTERS TO THE EDITOR

Noise and Signal ♦ Q-meter Refinements ♦ Strobe and Stroboscope ♦ Secondary Interference Radiation ♦ Television—Cinema Comparisons

Assessing Receiver Sensitivity

I HAVE found recently in the technical Press a misconception about the perceptibility of radio signals. This, it seems, has been fostered by manufacturers' advertisements that "1 μV in will give so-and-so-many watts out," without stating what part of this wattage is noise and what signal.

I think it will interest readers to learn the results of an investigation into the performance of normal communication receivers. Representative figures, according to my measurements, are tabulated below:—

	Lowest Input in μV into Aerial to Obtain 20db Signal-to-noise Ratio		C.W.	
	R/T; 30% mod.	R/T; 70% mod.	R/T; 30% mod.	R/T; 70% mod.
National HRO ..	3-5	1.5-2.5	1.5-2.5	1.5-2.5
Army R107 ..	3.5-5	2-3	2	-2.5
RCA AR88 ..	4.5-8	2.5-4.5	2.5-4	
Hallionrafters SX28	5-8	2.5-4.5	3	-4

These figures suggest that:—

- 5 μV in for 20 db signal-to-noise ratio on R/T (30 per cent mod.),
- 2.5 μV in for 20 db signal-to-noise ratio on R/T (70 per cent mod.),
- 2.5 μV in for 20 db signal-to-noise ratio on c.w.

is a fair average. We can therefore deduce that there is about 0.5 μV noise in these sets, and that signals of less than 1.5 μV on R/T (30 per cent mod.) or 0.8 μV on c.w. are useless, as they are not perceptible.

This does not suggest that we could not do better. A triple-diversity receiver specially developed for the Army (a prodigious 84-valve affair) gave 2 to 2.5 μV in for 20 db on R/T 30 per cent mod. and 1 to 1.5 μV for c.w., which brings the perceptibility down to 0.7 μV in for R/T and 0.5 μV for c.w. But that seems to be the limit at present.

K. E. MARCUS.

Uxbridge, Middx.

"Q-Meter Controversy"

IN the discussion on Q meters, both resistance and inductance methods of series injection have been referred to, and V. A. Sheridan has described a shunt-capacitance method.¹ This has also been treated at length by A. J. Biggs and J. E. Houldin.² It has

¹ *Wireless World*, June 1949, p. 217.

² "The Development of Q-Meter Methods of Impedance Measurement," *J. Instn elect. Engrs*, July 1949, Vol. 96, Part III, p. 295.

the practical disadvantage of requiring a special ganged variable capacitor, but seems otherwise to be very close to the ideal.

I have seen no mention of series-capacitance injection, however, and this would seem to offer some advantages. The basic arrangement is sketched in Fig. 1; the injected voltage is $e_1 / (1 + C_2 / C_1)$. The range of tuning capacitance is restricted by C_1 and C_2 coming in series with C , but C_2 can usually be large compared with C and, in any case, there is rarely any difficulty in making C rather larger than is customary.

Probably the most serious defect of the arrangement is the inevitable internal inductances of C_1 and C_2 . This will not affect the magnitude of the injected voltage if the ratio of the inductance is the same as that of the capacitive reactances (the inverse of the capacitances), but since C_2 is one hundred or more times C_1 this will rarely be the case.

It is, however, possible to use a capacitive ladder attenuator as shown in Fig. 2 (a). If all the capacitors C_1 have the same capacitance, are of the same

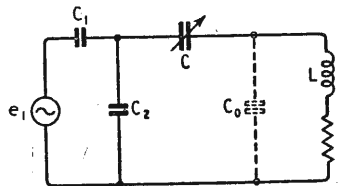

Fig. 1.

physical construction, and are wired with the same length of leads, their impedances are always equal and the overall attenuation is independent of frequency. The five sections shown make the equivalent injected voltage $e_1 / 89$; six sections would make it $e_1 / 233$ and four sections $e_1 / 34$.

The output capacitance of five sections (that is, the effective capacitance in series with C) is $1.62C_1$, and the input capacitance is $0.616C_1$. By repeated application of the star-delta theorem it is easily shown that the circuit has the exact equivalent of Fig. 2 (b). Save for the shunt input capacitance of $3C_1 / 5$ which plays no part in the attenuation, since the source is assumed to be of zero internal im-



THE "FLUXITE QUINS" AT WORK

"We'll be needing the FLUXITE" cried OH

"Must solder this earth wire, y'know.

This wire just won't reach,

Give a pull on it, peach,

That's plenty! I think that'll go."

See that FLUXITE is always by you — in the house — garage — workshop — wherever speedy soldering is needed. Used for over 40 years in Government works and by leading engineers and manufacturers. Of all Ironmongers—in tins, 10d., 1/6 & 3/-

TO CYCLISTS! Your wheels will NOT keep round and true unless the spokes are tied with fine wire at the crossings AND SOLDERED. This makes a much stronger wheel. It's simple—with FLUXITE—but IMPORTANT.

The FLUXITE GUN puts

FLUXITE

where you want

it by a simple

pressure. Price

2/6, or filled, 3/6



ALL MECHANICS WILL HAVE

FLUXITE

IT SIMPLIFIES ALL SOLDERING

Write for Book on the ART OF "SOFT" SOLDERING and for Leaflets on CASE-HARDENING STEEL and TEMPERING TOOLS with FLUXITE. PRICE 1d. each.

FLUXITE LTD.

(Dept. W.W.), Bermondsey Street, S.E.1

Letters to the Editor—

pedance, this circuit is identical with that of Fig. 1.

The main disadvantage of the circuit would seem to be the high input capacitance across which the source must develop the voltage e_1 . If $C_1 = 500 \text{ pF}$, the input capacitance

used in radar displays of the Gee and Loran type. This is a very fast time base, which can be started at any point in the fundamental repetition cycle of the radar system, thus permitting examination of the events at that point.

Mr. Gibson's wobblulator calibra-

interference to normal broadcast reception.

The only way such a system can cause interference is by acting as a conductor and re-radiator of interfering signals, generated by some external source.

It is hardly fair, therefore, to make a bald statement that wire broadcasting cables can and do radiate interference without stipulating that they are not the primary cause of the interference and that they are also only one of a very large number of such possible carriers.

K. A. RUSSELL,
Chief Engineer, British Relay
Wireless, Ltd.
London, W.C.2.

[Although the Belling-Lee statement was factually correct, it might have been stressed that secondary radiation of interference was in mind. However, the word "re-radiate" was in the heading of the paragraph.—ED.]

Drawing Circuit Diagrams

J. W. GODFREY, writing in your July issue, appears (to further scramble his metaphor regarding cruelty to horses) to forget that the vehicle which he uses to express his opinion—i.e., *Wireless World*—to which the horse is harnessed, still uses bridges and 4-way joints.

B.S.530:1948, p. 16, shows the "bridge" with the note, "The bridge is deprecated unless considered essential."

I still consider bridges essential if the draughtsman refuses to dispense with 4-way junctions.

As to errors in connection with blobs. A "blob-less" crossing was repeatedly re-photographed. In the later photographs spurious blobs of successively increasing size appeared, possibly owing to some sort of halation in the negative.

I use the method (a small arc near the T-junction) mentioned in Mr. Godfrey's letter only when correcting a drawing, as an indication to the draughtsman to re-draw the junction with a "tangent quadrant" as in the first sketch in the third column of my article in your May issue.

L. BAINBRIDGE-BELL,
Haslemere, Surrey.

"Televising Moving Images"

R. W. HALLOWS presumably finds the cinema satisfactory in the portrayal of movement, judging by the end of his article in your August issue. However, he seems to have misunderstood the technique of the film, set a trap for himself, and duly sprung it.

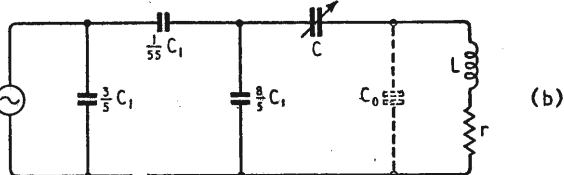
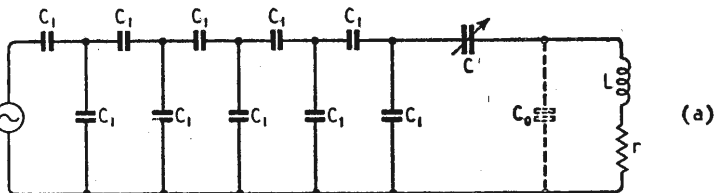

Fig. 2.

is 308 pF and the output is 810 pF . With $C = 1,000 \text{ pF}$, a maximum effective capacitance for tuning L of $1,000 \times 810 / 1,810 = 447 \text{ pF}$ is obtained.

W. T. COCKING.

"Strobing" Defined

WITH reference to R. C. Windsor's comments on the strobe principle (August), I beg to suggest that the following would be an adequate formal definition:—

Strobe (noun): A means of examining the instantaneous position or state of a cyclic phenomenon at regular intervals approximating to the fundamental cyclic period of the phenomenon or an integral multiple thereof. (Verb): To use a strobe.

Stroboscope: Apparatus for making visible the data obtained by strobing.

L. H. Bedford¹ defines two types of strobe: the heterostrobe, whose repetition frequency differs from that of the observed phenomenon, and the homostrobe, which has the same frequency as the observed phenomenon. He also expresses preference for the adjective strobic, rather than stroboscopic.

The oscilloscope may be regarded as a refined form of stroboscope using an infinitely large number of strobos, each of which examines one point on the displayed waveform. The term strobe can be applied with greater accuracy to the time base

would exist if the wobblulator were replaced by an alternative system.

Incidentally, Mr. Windsor need not look to the American literature for an anticipation of the idea of calibrating wobblulators. Similar techniques were in use in this country ten years ago, and refinements are discussed in a paper of mine written long before the American device appeared.²

D. W. THOMASSON.

E.A.R.L., Exeter.

Interference

THE following statement appears in Messrs. Belling & Lee's advertisement in your July issue:—

"We have recently been asked to confirm whether or not 'wires used for wired wireless' radiate interference. The answer is that they can and do. So do telephone wires and overhead fire-alarm wires, but, of course, the worst offenders are overhead mains in villages where the houses are wired with v.i.r. taken in at roof level."

I should like to emphasize that no signal capable of interfering with radio reception is injected intentionally by the operators of a wire broadcasting system, and in fact they are not allowed to do so by the stringent conditions of the Postmaster-General's licence.

Carrier distribution occupies the band 30-150 kc/s approx. and is also strictly controlled by the G.P.O. so that it can cause no

² D. W. Thomasson: The Principles and Practice of Panoramic Display, *J. Brit.I.R.E.*, VIII, 4, 17x.

¹ L. H. Bedford: The Strobe Principle in Radio and Radar, *J. Brit.I.R.E.*, VIII, 2, 62.

The number of black-out periods only affects flicker. The apparent smoothness of movement is fixed by the number of sequential and different transparencies projected in any one second (in this case 24). If an object in the scene shown is moving too fast for this repetition rate, the multiple image effect will be perceived in the eye, whatever the black-out rate may be. Incidentally, there are only two light cuts per frame in the normal sound projector; one for the picture shift and one intermediate. Provided these dark periods are of equal duration and equally spaced in time, there is no flicker apparent to the eye. It would merely be a waste of expensive light to increase the frequency.

As Major Hallows' article appears to plead that television should aim at the efficiency of the cinema, and his argument is based on a wrong premise, such argument would seem to break down. Nevertheless, perhaps the matter may be pursued a little further. If we assume his example of an image crossing the screen in one second, then, if the image were a vertical rod at high contrast (perhaps not a very usual or desirable part of television entertainment) the eye *might* be aware of the "lean" of one-fifth of an inch, but it is very much open to doubt. With the more normal type of image, such awareness may well be presumed impossible. With movements at such a speed the matter of interlace is likely to be unimportant. The image will be blurred in any case, but will probably show a 2:1 improvement over an attempt by the cinema to portray the same thing.

Having sacrificed much sleep to the elimination of hum effects caused by home-made a.c. not being at 50c/s, I feel certain that any change in frame repetition would have to be in multiples of that frequency. The Americans obviously adopted a frame speed of 60 per second to suit their mains supply. In fact they say so (see Terman and Fink on the subject*). To suggest that it would be nice to let the few fast movers go 20 per cent faster is just splitting hairs.

If there is an eventual change in the television standards in this country, it would seem preferable that any extra available bandwidth should be devoted to the provision of more lines. The inability of the present number to define long, narrow near-horizontals can be somewhat irritating, and is much more evident than any theoretical shortcomings due to the existing frame frequency.

Both the film and television set out to cheat the human eye by taking advantage of its defects. Any

OUR COVER

One of the two cruciform tiers of the Sutton Coldfield television aerial forms our cover illustration this month. The aerial system was designed by the B.B.C. Research Department in collaboration with the manufacturers—Marconi's WJT. Co. The outputs from both the 12-kW sound and 35-kW vision transmitters are carried by feeders to a combining unit whence they are fed to the elements so that a single aerial system can be used without mutual interference between the two transmitters. The eight compensated folded dipoles are fed in phase-quadrature so that the mast is virtually in a neutral field.

efforts at improvement of the media should be directed towards perfecting partial deceptions, rather than attempting to idealize those which are already more or less complete.

S. C. BARRELL.

Ashtead, Surrey.

* Terman: "Radio Engineering," 2nd edition, p. 747. Fink: "Principles of Television Engineering," p. 51.

NEWS FROM THE CLUBS

Birmingham.—Television construction will be discussed at the meeting of the Slade Radio Society at the Parochial Hall, Slade Road, Erdington, at 7.45 on September 16th. At the next meeting (September 30th) a talk on the theory and design of Class C amplifiers will be given. Members are holding a midnight d.f. test on October 2nd. Sec.: C. N. Smart, 110, Woolmore Road, Erdington, Birmingham, 23, Warwick.

Birmingham.—Members of the Midland Amateur Radio Society, which meets on Tuesdays at the Imperial Hotel, Temple Street, Birmingham, will be spending the week-end under canvas from September 10th to 11th. Details are available from the Sec.: A. W. Rhodes, 135, Woolmore Road, Birmingham, 23, Warwick.

Derby.—Apparatus constructed by members of the Derby and District Amateur Radio Society will be shown at the exhibition organized by the Derby Society of Model and Experimental Engineers to be held in the Queens Hall, London Road, Derby, from Sept. 20th to 24th. Sec.: F. C. Ward, G2CVV, 5, Uplands Avenue, Littleover, Derby.

Walsall.—Membership of the recently formed Radio Amateurs' Club of the Walsall Technical College is restricted to students or past students of the college. The club meets on Wednesdays in Room G, Wisemore Annexe of the College, at 7.30 p.m. Sec.: J. F. Young, Walsall Technical College, Bradford Place, Walsall, Staffs.

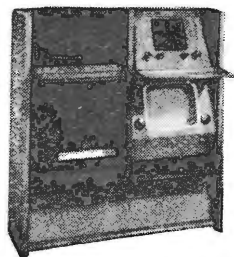

3 INSTRUMENTS IN ONE CABINET

plus built in record storage. With Pye radio and Television, Garrard auto-changer, storage space incorporating the well known IM RAK, and cabinet designed and built by Imhof's, this set offers you, at £145 (plus purchase tax), complete home entertainment for the lowest figure yet. This set, exclusive to Imhof's, will be displayed on our stand No. 89 in the Grand Hall at Radiolympia.

IMHOF'S

112-116 NEW OXFORD STREET, LONDON, W.C.1

In the electronics section, on our stand No. 183, we are exhibiting a selection of metal cabinets and instrument cases from our stock range and 'specials', including the new Enclosed Racks in 4' and 6' sizes illustrated below. Write for catalogue, giving details of our specialized metal cabinet production and design service, and complete range of standard cases available from stock.

ENCLOSED RACKS

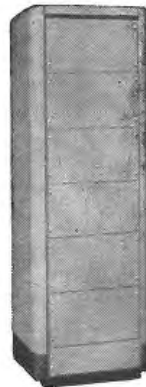

RANDOM RADIATIONS

By "DIALLIST"

Television Aerials

It's DIFFICULT not to feel that a good deal more skill and care might be used with advantage in the erection of television aerials. One knows, of course, that in areas where the field strength is good and interference severe it often pays to use the "inactive" member of an H-type assembly as a shield rather than a reflector. One knows, too, that, owing to reflection effects by buildings and so on, signal strength is not always at its best if an H-type assembly is set up by map and compass to point directly towards the transmitting aerial. But these things are hardly sufficient to account for what in some places looks almost like random setting up of the aerials! In some areas you may see aerials directed to almost every point of the compass! Notice, again, how many plain dipoles and H assemblies are a long way from being vertical. In some cases this *may* be right enough; but I fancy that few of them are intentionally out of the vertical plane in order to counteract reflection effects on the polarization of the incoming waves. And I'm sure there are no calculations, deliberations or tests behind the erection of an H-type aerial as an H. Nor do I feel that an assembly of this kind put up so that, when viewed from the direction in which it is pointing, it forms a tall, narrow X—the aerial sloping one way and the reflector the other—does much credit to the serviceman or owner who erected it.

A Stitch in Time

YOU KNOW THE OLD SAYING that it's the cobbler's children who go worst shod. We wireless folk are apt to give proof of the truth of its meaning by the way in which we so often take our domestic electric wiring for granted, never giving a thought to possible lurking dangers due to the stupidity of those responsible for its installation, maybe years ago. Not long ago a friend of mine came across a piece of work which might have had disastrous results. It had gone unsuspected for more than ten years.

It might have disclosed itself by giving a fatal shock, or by inflicting severe burns; luckily, the tell-tale shock was mild and it was received by one who realized at once that something was radically wrong and took appropriate action. A most undesirable state of affairs in the domestic circuits was found ultimately to be due to an almost incredible act of folly by the man who had done the wiring. It might happen in any house and escape notice for years; but it is so potent a source of danger that I make no excuse for telling you all about it. Briefly, my friend received a shock on touching the chassis of a radio receiver plugged into a wall socket which was switched off. The natural deduction was that the switch controlling the socket was wrongly wired—breaking the neutral and not the phase lead. The socket was one of three power outlets connected to three separate circuits on the ground floor of the house. Examination of each of the

three switches showed that they were correctly arranged so as to break the red wire. The power circuits were taken from a three-way distributor panel near the meter and their three red leads were on the correct side of this panel. Everything looked all right, but a neon tester showed that at the output side of the distributor and at all the three outlets the black was the phase lead and the red the neutral. What had happened was that the "tails" from the meter had been connected the wrong way round to the input side of the panel. Hence all the power outlets were "alive" when switched off—and one of them was in a concrete-floored scullery.

A Capacitor Teaser

RECENTLY a reader sent a very old paper-dielectric 0.1- μ F capacitor which, he averred, was showing an e.m.f. of 1 volt across its terminals on a valve voltmeter. The only v.v.-m available at the moment had an input resistance of 10M Ω . Applied to this, the capacitor registered an indubitable steady e.m.f. of 0.4V. Quite a few ancient paper capacitors were nestling in the junk boxes of the room, which, incidentally, is very dry. Tests were made on these

WIRELESS FOR SMALL CRAFT

General-purpose Receiver and Short-wave Radiotelephone

A COMPACT transmitter-receiver designed especially for use in yachts, motor launches and other small craft has been introduced by Pye Telecommunications, Ltd., Ditton Works, Cambridge. This

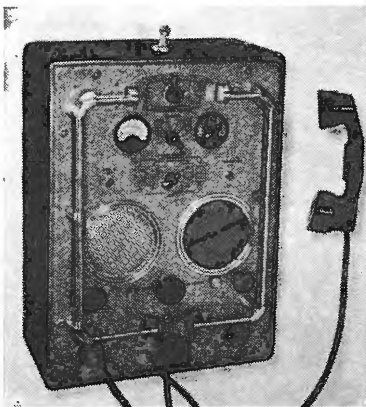

Pye Dolphin radiotelephone and general-purpose receiver for small craft.

set, which is known as the "Dolphin," is fitted with a five-valve superhet receiver covering 3,800 to 530 kc/s (79 to 567 m) and a crystal-controlled transmitter for sending on up to eight spot frequencies in the band 3,800 to 1,520 kc/s (79 to 197 m). The r.f. output is between 8 and 10 watts and amplitude modulation is used.

Housed in a single metal cabinet measuring 21 x 15 x 9 in and weighing 39 lb, the Dolphin is suitable for either shelf or bulkhead mounting. All the parts are assembled on the front panel, which simplifies servicing when the need arises. The inclusion of rubber seals between the panel and the cabinet and a hard-wearing finish render the set particularly suitable for shipboard use.

The equipment operates from either 6 or 12 volts and is particularly economical in its power demands. The receiver takes 0.5 amp only at 12 volts and the transmitter 8.3 amps.

A loudspeaker, as well as a hand telephone-microphone set, is included and the price is 75 guineas, less crystals and aerial.

and several showed e.m.f.s of 0.1-0.2V. Can any reader suggest how and why old capacitors should turn themselves (given the right conditions) into primary cells? It seems hardly likely that the e.m.f.s. can be residual charges which have persisted all this time—17 years in the case of the sample sent by the reader—in face of the cosmic-ray bombardments that must have been experienced for so long. There must, I feel, be some strange electro-chemical action; but what it is and why it occurs I don't pretend to know. There is clearly considerable activity on a small scale within old capacitors that behave in this way, for even a 0.1-volt e.m.f. causes several billion electrons to bustle every second through a 10-megohm load!

Soldering Iron Stands

A KIND READER sends me particulars of a simple but very effective prop that he uses for his soldering iron. You may recall that I commented a month or two ago on the queer failure of manufacturers to provide their otherwise excellent electric irons with props which would enable them to be put down whilst hot without doing damage to bench, table top and so on. My own method, as I mentioned, is to use a "bulldog" paper clip, having shaped the jaws suitably and bent the ears outwards. The reader in question writes: "Your idea has the defect that you have to turn the iron so that the feet are at the bottom before putting it down. Mine removes this defect, costs nothing for materials and takes only a few minutes to make. Cut a strip about one inch wide and three inches long from a tin can; bend the middle of the strip about three-quarters round the neck of the iron, splay out the free ends and the job is done. No matter how the iron is moved about in use, it always lands, catlike, on its feet." A good suggestion, you'll agree; but I personally don't like to have my prop on the bit itself—it gets in the way too often. Many irons have oval bodies and for these I think that my "bulldog" paper clip idea best fills the bill.

For Very Fine Work

DURING the past few days I've been trying the little "pencil" electric soldering iron made by Ekco. It's about the size of a fountain-pen

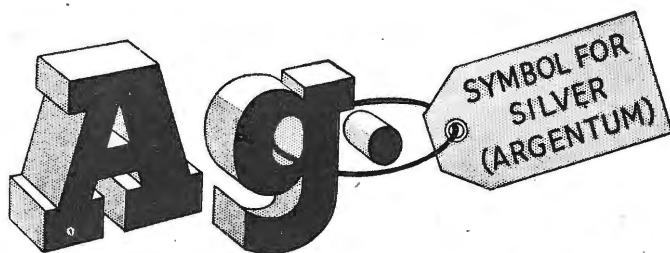

FOR LONG LIFE
MINIATURE SWITCHES

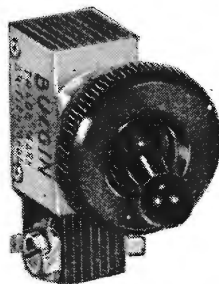

List No. S. 185

Bulgin Toggle Switches have Contacts and Tags or Terminals coated with pure Silver-Ag., because this precious metal inhibits high- Ω corrosion, giving low- Ω contacting, best heat-conduction (minimised sparking), and facilitates soldering to tags.

Bulgin Switches use tropical-grade insulation; have their steel cases copper- and nickel-plated; have ample cable-capturing terminals; have firm but smooth snap-action; are guaranteed for 25,000 ops. at rating (many give users $\frac{1}{4}$ -million ops., ten times what we claim); are available in Nickel, Chrome, Bronze, and Plastic colour finishes; AND—there are over a thousand varieties.

FACTS ABOUT SILVER

Melting Point 960° C.

S.G., 10.5 at 20° C.

Specific Resistivity ρ 1.62 $\mu\Omega/cm^3$

(Copper = 1,682)

Sulphide disrupts at low V.

Oxide not normally produced in air.

The Choice



of Critics

FOR OVER 25 YEARS

BULGIN

See us on Stand No. 1 at Radiolympia

NEW ILLUSTRATED CATALOGUE NOW AVAILABLE TO THE TRADE
A. F. BULGIN & CO., Ltd., BYE-PASS ROAD, BARKING

Telephone: RIPpleway 3474 (5 lines)

Random Radiations—

and does not weigh much more. The model I have is rated at 12 volts. The makers claim that it reaches the proper temperature in about a minute, but that seems to be slightly optimistic. My transformer gives a little over 12 volts under load and I find that the time needed for warming up to the temperature I like for 60/40 cored solder is nearer two minutes than one. That, however, is no great drawback, and this little iron is certainly a joy to use for those jobs of fine work which call for a light, handy tool and a small bit. It could be made almost perfect were two additions contrived. The first of these, I need hardly say, is a prop enabling it to be put down anywhere. The second is some form of temperature control. Unless the iron is used almost continuously (as is unlikely to be the case) the temperature of the bit increases rather rapidly. In the course of a series of tests I found that it rose to over 320 deg. C in six minutes—and was still rising. For normal fine soldering work one

doesn't need bit temperatures above 230 to 250 deg. C. Higher temperatures lead to pitting of small bits and don't usually make for long life of the heater coil.

French Television

TRANSMISSIONS of 819-line television have already begun from the temporary station in the Eiffel Tower. The power output is now only about 100 watts, but this is to be put up by stages to an eventual 5 kW. For the time being the transmitter will be at work for only an hour a day. Given a receiver of adequately wide-band type, great things can, of course, be done with such a system. *Toute la Radio* publishes a reproduction of the test pattern which has been adopted for the system. It is by far the most exacting thing of its kind that I have seen and any receiver which can do it full justice must indeed be a good one. I gather that French television enthusiasts are not altogether happy about the decision to close down the present 455-line transmissions nine years

**MORE COPIES OF
"WIRELESS WORLD"**

The Government's decision to increase the allowance of paper for technical periodicals is making it possible to print more copies of *Wireless World*. There should now be enough for all anticipated requirements. The number of copies is, however, limited, and it is, therefore, necessary for an order to be placed with a news-agent.

from now and to replace them entirely by those of 819 lines. There's a feeling that 819-line definition (supposing that the problem of making suitable wide-band receivers at a popular price is solved) may fall between two stools. It may be too good for small-screen domestic use and not quite good enough for big-screen work. Myself, I wouldn't like to hazard a guess about the future, for in these times of rapid progress an awful lot can happen in a very few years.

AIRPORT TRANSMITTER**Two-channel V.H.F. Equipment with Remote Control**

STANDARD TELEPHONES AND CABLES, Connaught House, Aldwych, London, W.C.2, have introduced a new v.h.f. transmitter which has been designed especially for ground-to-air communications. Recent investigations have revealed that at certain airports it was often required to transmit on either one

of two frequencies with rapid change from one to the other, or on both simultaneously, using the same microphone.

Meeting this requirement, the new type DU2 transmitter is a dual-channel set having two separate v.h.f. transmitters each rated at 50 watts output and capable of being operated singly, or together, from common modulator and power supply units.

Full remote control facilities are incorporated and the operator can select at will either one or both of the frequencies on which the two transmitting units are lined up. With the present models these must

lie in the band 115 to 135 Mc/s, but later models will have the frequency range extended from 70 to 150 Mc/s. Telephony or m.c.w. can be used.

The transmitters, modulator and power supplies are housed in a single cabinet with a flush-fitting door and measuring 3ft 8in x 2ft x 1ft 9in. An inclined panel at the top carries meters and local switching controls.

All units are accessible from the front for maintenance purposes so that the cabinet can be fitted with its back flush against a wall. The top unit containing the two r.f. transmitters and modulator slides forward on telescopic rails and it can also be swung into the vertical, giving access to the under-chassis components. The lower unit contains the power supplies and it can be pulled forward on rollers.

Normally the set is operated with the door closed and gate switches remove all dangerous voltages if any unit is withdrawn. Provision is, however, made for closing these by hand so that the equipment can be tested in the withdrawn position.

The transmitter is designed for operation in all climates; transformers are hermetically sealed and all components are tropicalized and conservatively rated. In addition, forced-air cooling is used.

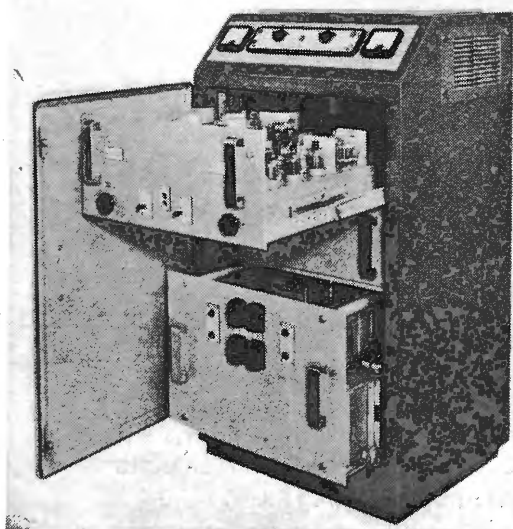

The new Standard Telephones and Cables 50-watt two-channel v.h.f. transmitter with door open and top and bottom units pulled forward.



Standard Miniaturized Crystals

THE smallest of their kind (Actual size $\frac{31}{32}$ " x $\frac{3}{4}$ " x $\frac{1}{4}$ ") Standard QUARTZ CRYSTALS (Type 4039) are artificially aged, hermetically sealed and robust to \pm degree. They are thus highly suitable for use in miniaturized stabilizing circuits of the highest stability and capable of withstanding the considerable shocks, heavy vibration and the widely varying climatic conditions which are inseparable from Service conditions.

Typical of Standard's attention to detail is the handy finger grip for easy insertion and removal of the QUARTZ CRYSTAL.

Standard Telephones and Cables Limited (TELEPHONE LINE DIVISION)

Registered Office: Connaught House, Aldwych, London, W.C.2

NORTH WOOLWICH, LONDON, E.16.

Telephone: Albert Dock 1401

INDEX TO ADVERTISERS

Table listing advertisers and their page numbers. Columns include Advertiser Name, Page, Advertiser Name, Page, Advertiser Name, Page. Includes entries like A.A. Tools, Acru Electric Tool Mfg Co., Ltd., Ad. Ariema Inc., etc.

Advertisement for OXLEY AIR DIELECTRIC TRIMMER. Features the text 'TECHNICAL EXCELLENCE' and 'OXLEY AIR DIELECTRIC TRIMMER'. Includes a photograph of the trimmer and technical specifications: Width: 13.5 m.m., Length: 22 m.m., Height: 1.5 to 8pF-7.5 m.m., 1.8 to 20pF-10 m.m., 2 to 26pF-11 m.m., 2 to 32pF-12 m.m. Law: Straight line capacity. Power Factor: Less than .001. Insulation: Over 2,000 megohms. Voltage: 500 D.C.

Advertisement for Cyldon MICA-DIELECTRIC Trimmer CAPACITORS. Features the text 'Cyldon' and 'MICA-DIELECTRIC Trimmer CAPACITORS'. Includes a photograph of the capacitor and dimensions: 1 1/2" long, 1/2" w.de., 1 1/2" high. Text: 'Type No. 19'. Company: SYDNEY S. BIRD & Sons, Ltd. CAMBRIDGE ARTERIAL RD., ENFIELD, MIDDLESEX. Phone: Enfield 2071-2. 'Grams: "Capcity, Enfield"'

Printed in Great Britain for the Publishers, LITTLE AND SONS LTD., Dorset House, Stamford Street, London, S.E.1, by THE CORNWALL PRESS LTD., Paris Garden, Stamford Street, London, S.E.1. "Wireless World" can be obtained abroad from the following-AUSTRALIA and NEW ZEALAND: Gordon & Gotch, Ltd. ENGLAND: A. H. Wheeler & Co. CANADA: Imperial News Co.; GORDON & GOTCH, Ltd. SOUTH AFRICA: Central News Agency, Ltd.; WILLIAM DAWSON & SONS (S.A.), Ltd. UNITED STATES: The International News Co.

NOTICE

"POINT ONE" is the Trade Mark of H. J. Leak & Co., Ltd. It was originally applied to the first power amplifiers having a total distortion as low as point one of one per cent, when in June, 1945, H. J. Leak, M. Brit. I.R.E., revolutionised the performance standards for audio amplifiers by designing the original "POINT ONE" series.

NEW LEAK "POINT ONE" AMPLIFIERS

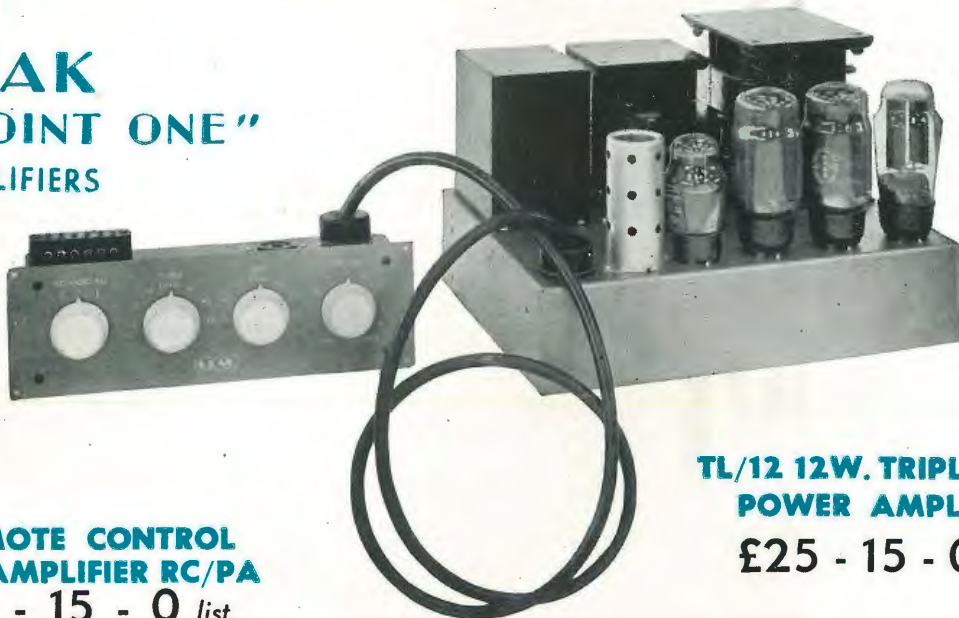

**REMOTE CONTROL
PRE-AMPLIFIER RC/PA**
£6 - 15 - 0 list.

**TL/12 12W. TRIPLE LOOP
POWER AMPLIFIER**

£25 - 15 - 0 list.

An original feedback tone-control circuit which will become a standard.

No resonant circuits employed.

- Distortion: Less than 0.05%.
- Switching for Pick-up, Microphone and Radio, with automatic alteration of tone-control characteristics.
- High sensitivities. Will operate from any moving-coil, moving iron or crystal P.-U.; from any moving-coil microphone; from any radio unit.
- Controls: Input Selector; Bass Gain and Loss; Treble Gain and Loss; Volume.
- Output Impedance: 0-30,000Ω at 20 kc.p.s.

The unit will mount on motor-board through a cut-out of 10½ in. × 3½ in., or it can be bolted to the power amplifier, when, with a top cover, the whole assembly becomes portable.

For use only with LEAK amplifiers.

Used with the RC/PA pre-amplifier and the best complementary equipment the TL/12 power amplifier gives to the music-lover a quality of reproduction unsurpassed by *any* equipment at *any* price. It is designed in a form so that the power amplifier can be housed in the base of a cabinet and the small pre-amplifier mounted in a position best suited to the user.

A Leak triple loop feedback circuit, the main loop giving 26 db. feedback over 3 stages and the output transformer.

- Push-pull triode output stage. 400 V. on anodes.
- No H.T. electrolytic smoothing or decoupling condensers.
- Impregnated transformers; tropically finished components.
- H.T. and L.T. supplies for pre-amp. and radio units.
- Distortion: at 1,000 c/s and 10 W. output, 0.1%; at 60 c/s and 10 W. output, 0.19%; at 40 c/s and 10 W. output 0.21%.
- Hum and Noise: -80 db. on 10 W.
- Frequency response: ±0.1 db., 20 c/s-20 kc/s.
- Sensitivity: 160 mV.
- Damping Factor: 20. Input impedance: 1 MΩ
- Output impedances: 2Ω; 7-9 Ω; 15-20 Ω; 28-36 Ω.

25 W. model available at £27.10.0.

★ If you are interested in high-fidelity reproduction or recording you are certain to find our 16-page illustrated booklet of considerable value. It is presented in a form acceptable both to the professional communications engineer and to the amateur enthusiast seeking the highest possible quality of reproduction. ★

WRITE FOR BOOKLET W/TL/12

H. J. LEAK & CO. LTD. (Est. 1934)

BRUNEL ROAD, WESTWAY FACTORY ESTATE, ACTON, W.3

Phone: SHEpherds Bush 5626.

Telegrams: Sinusoidal, Ealux, London.

Foreign: Sinusoidal, London.

Remember **ERSIN MULTICORE SOLDER** at the last Radiolympia?



The Finest Cored Solder in the World

Whether for manufacture or maintenance of Television, Radio or Telephone equipment, Ersin Multicore Solder has been found by manufacturers in Britain and U.S.A. to be the most economical as well as the most efficient solder.

Only Ersin Multicore contains extra-active, non-corrosive Ersin Flux enabling joints to be made on heavily oxidised surfaces. Only Ersin Multicore with its 3 core construction gives guaranteed flux continuity, instantaneous melting and guaranteed freedom from 'dry' or H.R. joints.

Ersin Multicore Solder as used by the leading Television, Radio and Telephone manufacturers, is available from most retailers in Size 1 cartons in the specifications shown below.

Catalogue Ref. No.	Alloy Tin/Lead	S.W.G.	Approx. Length per Carton	List Price per Carton (subject)
C16014	60/40	14	32 feet	s. d. 6 0
C16018	60/40	18	84 feet	6 9
C14013	40/60	13	20 feet	4 10
C14016	40/60	16	44 feet	5 3

Remember the assembly line on the Ersin Multicore stand, where over a million parts of radio sets were assembled and 38,500 Multicore soldered joints made?

At the 1949 Radiolympia, Multicore will have the co-operation of E.M.I. Factories Ltd. On stand No. 84, R.F. units of "His Master's Voice" Television receivers Model 1807, will be assembled and Multicore soldered.

In this "model factory" the care and precision of E.M.I. manufacturing processes will be seen. Each R.F. unit manufactured on the Multicore stand will involve the assembly of 47 parts, including 8 valves and the making of 117 Ersin Multicore soldered joints.

7 lb. reels are preferred by most manufacturers. Bulk prices upon request. Size 1 cartons for service engineers and workshops.



MULTICORE SOLDERS LTD.

Meilier House, Albemarle St., London, W.1 • Tel: REGent 1411

Stands 83, 84
RADIOLYMPIA